



BRITISH BROADCASTING CORPORATION

MICROCOMPUTER SYSTEM

# Nucleus System Generator

for the BBC Microcomputer with Z80 second processor

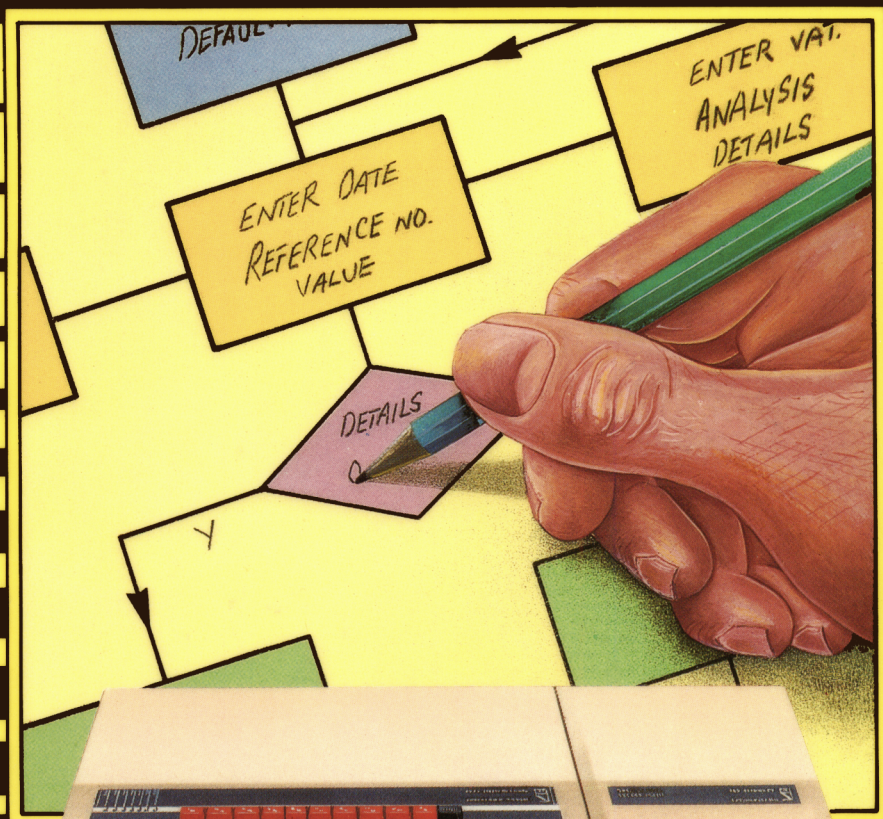



# Nucleus

---

## **Guide to the systems generator in the BBC Microcomputer Z80 Pack**

Part no 409009  
Issue no 1  
Date February 1984

Within this publication the term 'BBC' is used as an abbreviation for 'British Broadcasting Corporation'

© Copyright Acorn Computers Limited 1984

Neither the whole or any part of the information contained in, or the product described in, this manual may be adapted or reproduced in any material form except with the prior written approval of Acorn Computers Limited (Acorn Computers).

The product described in this manual and products for use with it, are subject to continuous developments and improvement. All information of a technical nature and particulars of the product and its use (including the information in this manual) are given by Acorn Computers in good faith. However, it is acknowledged that there may be errors or omissions in this manual. A list of details of any amendments or revisions to this manual can be obtained upon request from Acorn Computers Technical Enquiries. Acorn Computers welcome comments and suggestions relating to the product and this manual.

All correspondence should be addressed to:

Technical Enquiries  
Acorn Computers Limited  
Fulbourn Road  
Cherry Hinton  
Cambridge  
CB1 4JN

All maintenance and service on the product must be carried out by Acorn Computers' authorised dealers. Acorn Computers can accept no liability whatsoever for any loss or damage caused by service or maintenance by unauthorised personnel. This manual is intended only to assist the reader in the use of the product, and therefore Acorn Computers shall not be liable for any loss or damage whatsoever arising from the use of any information or particulars in, or any error or omission in, this manual, or any incorrect use of the product.

**Written and produced by Baddeley Associates, Cambridge**

First published 1984

Published by Acorn Computers Limited, Fulbourn Road, Cherry Hinton, Cambridge  
CB1 4JN

Typeset by MF Graphics Group, Saffron Walden, Essex

Z80 is a trademark of Zilog Inc

CP/M<sup>®</sup> is a registered trademark of Digital Research Inc

# Contents

---

<b>Conventions used in this guide</b>	<b>6</b>
<b>1 Nucleus</b>	<b>7</b>
<b>2 What Nucleus can do</b>	<b>8</b>
<b>3 An overview of the Nucleus programs</b>	<b>9</b>
The programs	9
The menus	10
<b>4 Designing a simple records system</b>	<b>11</b>
Planning your file structures	11
The questions to ask	13
Keys and links	16
Entering information and printing reports	17
The discs you need	17
Messages and prompts	18
Typing in your program details	18
<b>5 Setting up an example system</b>	<b>20</b>
Starting	20
Finishing a session	22
Defining a file	22
Creating a parameter file	22
Naming the system	23
Creating the program files	25
Field definition	26
Setting up the principal key	30
Writing a simple updating program	32
Using the School records program	35
Printing a simple report	37

---

**6 Planning keys and links** **41**

Deciding on the keys to use	42
Using links	43
Using keys for sorting	44
Master and transaction files	44
Designing an updating program	46

---

**7 Setting up a system with linked files** **47**

Linking files together	50
Writing more complex updating programs	52
Updating selected fields	53
Including validation and automatic updates	57
Running your new programs	59

---

**8 Planning reports, letters and other documents** **62**

Choosing the records to be printed and the printing order	63
Printing calculated values	64
Designing a report-writing program	65
Printing a specially-designed report	65
Writing a label-printing program	66
Designing a letter-writing program	67
Designing a document-writing program	67
Producing reports from Accountant files	68

---

**9 Producing a selected report-writing program** **69**

Using a computed field	71
Doing a test print	72
Printing order	73

---

**10 Producing a label-printing program** **76**

Specifying the print order	78
Selecting the data to be printed	78

---

**11 Producing a letter-writing program** **80**

Creating the text of the letter	84
Deleting a letter	90

<b>12 Producing a document-writing program</b>	<b>91</b>
Setting up the document program	93
Creating the text of the document	96
Deleting a document	107
<b>13 Printing details of your files</b>	<b>108</b>
<b>14 Amending menus</b>	<b>109</b>
<b>15 Using passwords</b>	<b>110</b>
<b>Error messages and potential pitfalls</b>	<b>113</b>
<b>Glossary</b>	<b>116</b>
<b>Index</b>	<b>118</b>

# Conventions used in this guide

---

In this guide, we use a set of standard notations to refer to keys on the keyboard, to commands you enter frequently with Nucleus, and to items you type in. The following examples will show how the conventions work.

**DELETE**

refers to a key – in this case, the key marked 'DELETE'

**cancel**

refers to a Nucleus command, which is controlled by a function key – see the Nucleus page of your key cards

<option number>

means type in an option number; do not type in the angled brackets

**CTRL** **BREAK**

means, while holding down **CTRL**, press **BREAK**



# 1 Nucleus

---

Nucleus is a system which writes computer programs. With it you can design your own programs, even if you have no programming experience, and Nucleus will write them for you. For more experienced programmers, Nucleus takes much of the time-consuming routine work out of software development.

You'll use Nucleus to write programs tailored to suit your own needs; programs which use the computer to handle large amounts of data and automate laborious tasks, which, up to now, you have had to do manually.

Nucleus is particularly useful for:

- developing your own database to keep, for example, records of stocks and shares, customers, suppliers or club members – anything, from personnel records to the families in a baby-sitting circle
- planning schedules, such as sports fixtures or play rehearsals
- printing reports from Accountant (the accounting program in the *Z80* pack) to suit the needs of your business
- designing reports to be printed out automatically from the programs which you've designed and Nucleus has written.

You'll find more examples of things you can do with Nucleus later in this guide and in the *Z80 user guide*. The more you use Nucleus, the more you will see how many problems Nucleus can solve.

The main part of the manual takes you step-by step through the stages of designing your own programs. It includes examples to set up, which illustrate what you have to do at each stage. Before you go any further, read the *Z80 user guide*. You will need in particular the information there on:

- setting up your equipment
- loading its operating system
- setting up your function key cards
- preparing working discs
- formatting blank discs
- making back-ups.

# 2 What Nucleus can do

---

Nucleus is a very powerful tool for setting up information systems. When you've used your Nucleus discs to write the programs you need you can put them away and run the programs themselves. You won't need Nucleus again until you decide to design a new system, or build on an existing one.

For the advanced programmer, Nucleus writes programs in BASIC which you can tailor to solve particular problems.

Nucleus is widely used by businesses, both large and small for a range of applications – from cost control in an engineering construction company to monitoring sales enquiries in a large stationery retailer.

The strength of Nucleus lies in its flexibility. You can use it to set up any number of files, storing very large amounts of data, and to write programs which will:

- allow information to be entered in the manner you specify
- allow you to review information in the files on the screen
- identify selected entries in the file for rapid sorting of information
- allow the person entering the information to check back against other files at the same time
- automatically update entries in one file from another, using calculations you specify
- print out a variety of different types of reports from the information in your records system
- protect your information, using passwords.

# 3 An overview of the Nucleus programs

---

Nucleus is split into a number of programs which work together to build up complete filing systems for you. How these programs are distributed on different discs will depend on how you set up your program and is explained in the next section.

## The programs

The main parts of Nucleus are:

**Nucleus Definition:** which sets up the file structures and writes the program you use to enter information.

**Nucleus Reporting:** which allows you to produce different types of report including:

- reports in columns, taking information from the files Nucleus Definition has set up
- reports that combine text and information from your record files, printed in columns
- reports which allow you to create standard texts and put information from your records into them, for example, a standard letter.

When you start to design a program you will be working with the Nucleus Definition disc.

When you have used Nucleus to build the files you need, you then use it to write the program which enables you to put information into them. This is called an updating program. You run this program to enter the details (such as names and addresses) which will make up your records.

At this stage you still cannot take information out of your records. To do this, you use Nucleus Reporting to write programs to print out reports, documents or letters using the information stored in the files you set up.

## The menus

Nucleus is a menu-driven program. This means that a series of choices will appear on your screen and you select the one you want by typing the number beside it followed by **RETURN**.

The screen prompts you to use the **RETURN** key by saying 'ENTER'. This is to reinforce the fact that you are entering information with this key.

Choosing a menu option is shown in the manual as:

Select <option number> from the menu.

The programs Nucleus writes for you are also menu-driven, and have menus built on the same pattern as Nucleus itself. As you define your program, Nucleus puts the information you type in into your own menu structures.

Each program has its own sub-menu which you select by typing the relevant number followed by **RETURN**. An overview of the main Nucleus menus is shown below:

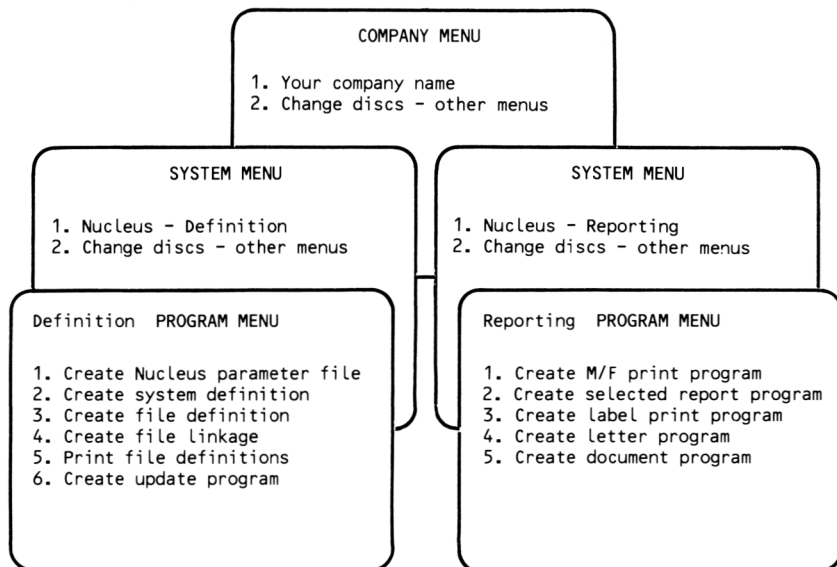

# 4 Designing a simple records system

---

This chapter explains how to design a simple program to be written by Nucleus. It explains the principles involved. Once you understand the concepts, entering the information becomes straightforward.

It includes how to:

- design the program you want Nucleus to write
- respond to screen messages and prompts
- type in the information Nucleus needs
- start the program running
- finish a session, when you need to.

Chapter 5 then shows you how to put the theory into practice by setting up a short example (a School records system) for you to follow.

## Planning your file structures

The most important part of designing a program for Nucleus to write is the planning stage. This section explains how to design a simple records system.

In its simplest form, Nucleus produces programs which give you the computer equivalent of a filing cabinet. It creates files on floppy discs to hold information for you. You could think of these as the drawers in a filing cabinet, each with its own name, the filename.

In each drawer of your cabinet you have a series of folders, called records.

Inside the folders are pre-printed forms. These are identical for all the folders in a drawer, and have spaces into which you put information. You define these forms with Nucleus, by specifying the spaces and what they should contain. These spaces are called fields.

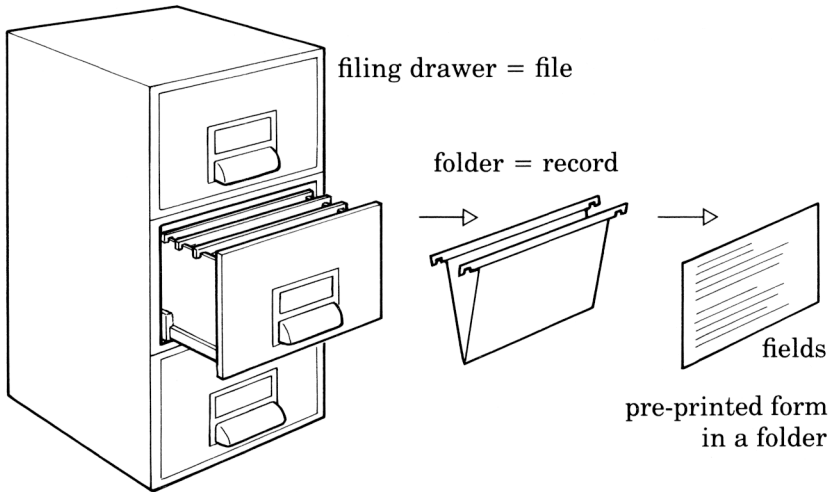

*If, for example, you were designing a system to hold the records for a school, your system might use two drawers of a filing cabinet:*

- *one for details of each student (called the Student file)*
- *one for details of when pupils were absent and why (the Absence file).*

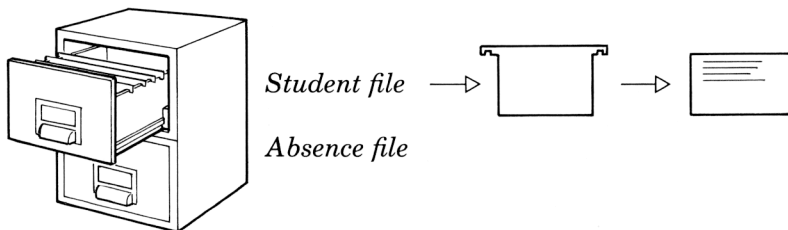

*A real school records system would probably have several more files than this, but this is enough to help you understand how to use Nucleus.*

*The top drawer would contain the details (records) of every student. Each record would hold the same pieces of information, defined in the fields but not every record will necessarily have all the fields filled in.*

*The folder cannot contain extra information which did not have a space allocated to it on the pre-printed form.*

This is a very simple example of the way Nucleus works. In practice, it will handle much more complicated and sophisticated applications, but you can understand the principles involved by working first on a straightforward application like this, which uses all the basic features of the program.

## The questions to ask

Now look at the steps involved in building a system with Nucleus.

Before starting to design your program, ask yourself the following questions.

- 1 What is the program for?
- 2 What information will I want to get out of it?
- 3 How should this information be set out?
- 4 Who will be using the program?
- 5 What information (records) should be kept by the program, to allow you to print out the correct information from the system?

### *Example*

*If you were setting up the School records system you might want the following information and reports from your program:*

- *lists of pupils*
- *students' names and addresses*
- *lists showing how many days each pupil has been absent.*

*Organise the information into files, each holding a particular type of information, for instance, students' names and addresses may be in one file; teachers' names and addresses in another.*

*The Student file would probably contain the following information:*

- 1 Student code*
- 2 Name*
- 3 Address*
- 4 Form number*
- 5 Date of birth*
- 6 Absence to date*

Each of these lines represents a field and will be automatically given a number by Nucleus when you define it.

At this point, if you were setting up a system, you would list all your fields on paper and write down the answers to the following questions so that you can enter the right information when you are asked to by Nucleus.

**What is the name of the field to be?**

When your program is finished and running, the field name can be displayed as a prompt for the person typing in information.

**What type of characters will the field contain?**

Will they be letters and numbers, or just numbers, or possibly a date?

**How many characters will you need in the field?**

For a name, for example, you could allow up to 15 characters.

**How many lines do you need?**

An address, for example, might take up five lines.

If the field contains only numbers:

**How many digits will you have before the decimal point?**

**How many will you have after the point?**

**Do you wish to allow negative values to be typed in?**

**Can you set minimum or maximum values? If so, what are they?**

**Do you want the record to be protected from deletion if this field has information in it?**

This means that unless that field contains a zero, the record cannot be deleted from the file.

When you design your own program you will need to answer these questions for all the different fields in your records. We have included an example of a planning sheet here, which you may find useful for this.





# Keys and links

Another important concept is the way you mark fields you want Nucleus to use for indexing records. This is called making a field into a key, which is like putting an identification tab on a folder in your filing drawer.

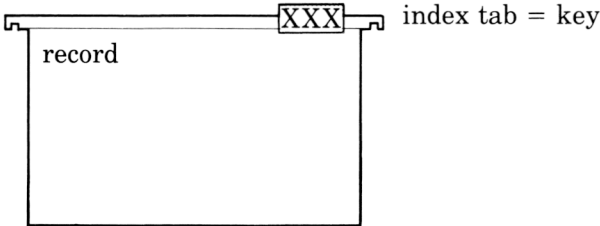

To find a particular folder, you would flick through the tabs, rather than looking into each one. In the same way, the computer filing system sorts through and prints out the information you want, using the keys to help it find records quickly. The program also stores records in the order of the keys you set up.

You also use these keys to link files to one another so that you can get at the information in two files in one operation – something you cannot do with a manual filing system.

How to set up these keys and links, and what they can do, is explained fully in chapters 6 and 7.

*In our first example, you only have to define one field in your Student file as a key – the Student code, which is the first field in the file.*

## Entering information and printing reports

Having set up your files, you need to write a program to put information into them. This is called an updating program.

To get information out, you need a program for producing printed reports. This allows you to extract information from your records and print it out in a variety of formats, for example, in columns, in a letter, or in other documents.

How to design your reports and select the information they are to use is explained in chapters 9 to 11.

## The discs you need

Following the instructions in the *Z80 user guide*, you will have created program discs from the discs you received with your Z80 pack. You may have used one for each part of the program or have combined more than one program on a single disc.

The **start-of-day** disc contains the operating system, utilities and special routines to set up the machine at the start of each session.

The **parameter disc** contains information about the file structures of the programs you are writing.

(The version supplied with the Z80 has details about the file structures of the nominal ledger in Accountant. This is so that you can extract information from your accounts by using Nucleus. When you set up the example you will not need access to Accountant's files, so you should make a new parameter disc to hold information about the file structures of the programs you are making. We will tell you how to do this later.)

The **Nucleus program discs** are the discs containing the Nucleus Definition and Reporting programs.

Each new program you design will be saved on a disc, which you should label as the **program disc**, with the program name. Each program disc may contain several programs, which you've produced using Nucleus.

Label all your discs clearly.

## Messages and prompts

Nucleus uses screen messages to tell you what is happening and when to change discs, and prompts to tell you what to type next.

Messages are shown in the guide like this:

```
message  Mount program disc on drive B
```

When this happens you should note the information or carry out the instruction, as appropriate.

Prompts are shown in the guide like this:

```
prompt  Details OK? (Y/N/END)
```

Whenever this happens you should enter the information requested for in the prompt.

## Typing in your program details

A cursor will appear at the point on the screen where the information is to go. You can then type in the details of the program you are setting up and press **RETURN** at the end of each item.

When you have entered all the information for that screen you will see:

```
prompt  Details OK? (Y/N/END)
```

```
or      Details OK? (Y/N/CAN)
```

You should then check the information you have entered and, if it is correct, type **Y RETURN** to move to the next step.

If it is wrong, type **N RETURN** to go back and change it. You can skip the lines which are correct, using **RETURN**, and type over those which are wrong.

Press **end** when you've finished a particular operation. You may then move on to the next operation or return to a menu.

Pressing **cancel** deletes all that you have typed in on a particular operation.

In this guide we show these options as:

Type	<b>Y</b>	<b>RETURN</b>	to accept the details
	<b>N</b>	<b>RETURN</b>	to amend them or to stop an operation
	<b>end</b>		to end the operation

or **cancel** to delete the details.

These prompts appear very frequently in the program, and so, in the manual, they are not repeated every time they appear. You will need to confirm the details are correct on every screen where you've typed in information.

If you want to change an entry, you can do so using **DELETE** before you've pressed **RETURN**.

To change information after you've pressed **RETURN**, continue until you see the prompt **Details OK? (Y/N/END)** or **Details OK? (Y/N/CAN)** and type **N**. You can then step through the information you've typed in, typing over that you want to change and leaving the rest unchanged by pressing **RETURN**.

# 5 Setting up an example system

---

This chapter takes you through how to:

- build a file using Nucleus
- enter information into it, and
- print out a report.

## Starting

Make sure both disc drives are empty, and that everything is switched on.

Flip over your function key cards until they are open at the Nucleus page. Not many of the keys are needed in Nucleus, but those that are you will find very useful.

Put the start-of-day working disc into drive A.

You have to use the start-of-day disc every time you use Nucleus or run programs you've generated with it.

If you need to load CP/M, press **CTRL BREAK**.

If you've been using a different program, type **CTRL C**.

Prompt A>

Type Start **RETURN**

You will now see a Copyright message while the program loads the software.

Prompt Please enter today's date (DDMMYY)  
( 'END' to exit program)

Type <day><month><year> **RETURN**

For example, if the date is 12th April, 1984, type 120484.

Prompt Date OK? (Y/N/END)

Type Y **RETURN** to accept the date  
 N **RETURN** to enter another date  
 end to leave the program.

Prompt Please load program disc on drive A  
 and file disc on drive B

Press 'ENTER' when ready...

Take out your start-of-day working disc and replace it with your working copy of the Nucleus Definition disc. Check that the disc does not have a write-protect patch on it. Put a blank, formatted disc in drive B. This will become your parameter disc.

Press **RETURN**

---

COMPANY MENU

1. Your company name
2. Change discs - other menus

---

This is the first display in the Nucleus program, and it is provided so that you can develop programs for more than one company and they will all be grouped together.

You can set up the example used here by selecting the first option on this menu. Later, if you want to change the entries, for example, by putting your own company name at the top, you can find out how to do so by looking at chapter 14.

Select 1 to see the second Nucleus menu.

---

SYSTEM MENU

1. Nucleus - Definition
2. Change discs - other menus

---

To move back from one menu to a previous one, press **RETURN** without typing in an option number.

## Finishing a session

The way you finish a session with Nucleus is very important. If you don't follow the correct procedures your data can be corrupted and you risk losing a lot of hard work.

If you have a Nucleus menu displayed on your screen you can leave the program by pressing **RETURN** several times, to step back through the menus and finally display the CP/M prompt **A>**.

If you are not at a menu, finish what you are doing and return to a menu before using **RETURN** to leave Nucleus. Make sure you have a disc containing the CP/M operating system in drive A so that you can return to the **A>** prompt.

## Defining a file

Select 1 from the system menu for **Nucleus - Definition**.

The first three options allow you to:

- create your parameter file
- name the system you are defining
- define the file structures it will contain.

---

Nucleus - Definition

PROGRAM MENU

1. Create Nucleus parameter file
  2. Create system definition
  3. Create file definition
  4. Create file linkage
  5. Print file definitions
  6. Create update program
- 

## Creating a parameter file

Before you can set up any files you need to make a parameter file to hold information about the file structure of the programs you create with Nucleus. You will only need to do this the first time you set up a program.



Select 1 from the menu for **Create Nucleus parameter file**.

Prompt Do you want to create Nucleus  
parameter file ? (Y/N/END)

Type Y **RETURN**

Prompt Mount Nucleus parameter file disc  
on drive B (CAN to cancel).

Make sure you have a blank, formatted disc in drive B, labelled  
'Nucleus parameter disc'.

Press **RETURN** and Nucleus will create the file.

Message Nucleus parameter file  
successfully created

WARNING: do not try to use the disc if this message doesn't appear –  
reformat the disc and try again.

If you try to create a parameter file when one already exists on the  
disc you will see:

message NUCLEUS PARAMETER FILE ALREADY EXISTS

Press **RETURN** to carry on.

You will now go back to the program menu.

## Naming the system

To name the program you are writing, select 2 for  
Create system definition.

Prompt Do you want to continue? (Y/N/END).

Press Y **RETURN** to continue.

System name .....  
System prefix

---

**System name** (up to 20 characters)

Enter the name of the system you are generating (in this example, **School records**). You should try to make the name a description of the system.

**System prefix** (2 characters)

Enter a suitable prefix. This distinguishes one system from another when files are created on the same disc. You should not use the same prefix for more than one system.

Note: the following prefixes are not recommended as they are used in Accountant and other follow-on accounting products:

IN IV NL PA PD PL SL SR

In our School records example, use **SC**.

You will then see:

prompt **Details OK? (Y/N/CAN)**

Type **Y** **RETURN** to accept the details.

Prompt **Mount School records program disc  
on drive B**

Label a formatted disc, 'School records program disc', put it in drive B and press **RETURN**. The program you are defining will be stored on this disc.

Prompt **NO COMPANY MENU EXISTS ON DRIVE B  
Please change disc or press C  
to create menu**

This means that, because you are starting a new disc, the menu structures have not yet been set up on it.

Type **C** **RETURN**

to put the empty menu on the disc. As you build up your program Nucleus will put entries into these menus, which are displayed when the program is run.

Prompt Mount Nucleus parameter file disc  
on drive B

Remove the School records program disc from drive B and insert the parameter disc, which needs to be present while you define a new system.

Press **RETURN**

You then return to the Nucleus Definition program menu.

## Creating the program files

---

Nucleus - Definition	PROGRAM MENU
	1. Create Nucleus parameter file
	2. Create system definition
	3. Create file definition
	4. Create file linkage
	5. Print file definitions
	6. Create update program

---

Now you start to set up the first file for your program.

Select **3** from the menu for **Create file definition**.

Prompt Select system (END)

The available systems are on the screen below the prompt. As you are using Nucleus for the first time there will be only one. Each system is given a number, starting from 20 since the numbers 1-19 are reserved for standard accounting packages, such as Accountant.

Type <system number> **RETURN**

The number in our example is 20. The name will appear at the top of the screen.

Prompt **Details OK?**

Type **Y RETURN** to accept the details  
**N RETURN** to amend them.

---

System number	20 School records
File number	1
File name (END)	.....
File type (M/T)	

---

Nucleus automatically numbers the files consecutively for you.

**File name** (up to 20 characters)

Enter the name of the first file in your system, or press **end** if you want to stop the operation.

Type **Student file RETURN**

**File type (M/T)**

Files can be of two types: **Master** files or **Transaction** files. The difference between them is explained in the next chapter.

For the Student file in the example, type **M** for master file. Nucleus will then save the details of the file you've specified.

## Field definition

Now you have to define each field in the file you have created and named. A field is the space allocated to hold an item of information. You have to tell Nucleus exactly what to expect to be entered in each field – how much space is needed, whether it will be numbers or letters and so on.

When the finished program is run, if someone enters data which does not match the specifications you've given to Nucleus, it will not be accepted.

---

System number	20 School records
File number	1 Student file
Field number	1
Field name	.....
Field type (A/N/D/R)	
Number of characters	
Number of lines	
Number of digits before point	
Number of digits after point	
Allow negative values?	
Minimum value	
Maximum value	
Delete protect?	

---

The cursor will move to each field for you to fill it in. If some are not applicable, it will skip them automatically. How to fill in each space is described below.

### Field number

This is entered automatically by Nucleus.

### Field name (up to 20 letters and/or numbers)

This describes the contents of the field and it is used to identify it when the program is created. In the example, type **Student code** for the first field in the Student file.

### Field type (A/N/D/R)

Enter the code which corresponds to the type of characters you want in this field, according to the following code letter definition:

- A** – for a field with letters only, or letters and numbers
- N** – for numbers only
- D** – for a date in the form DDMMYY
- R** – for a reverse input field to cater for entries in languages which are written from right to left.

In the example, type **N**.

The following two prompts occur only if you have set the field to contain letters and numbers (alphanumeric):

### Number of characters (1 to 50)

Enter the number of letters and numbers you want in the field.

**Number of lines (1 to 5)**

Enter the number of lines you want, for example, if the field is an address field, you would probably want 5 lines.

For fields containing numbers only (numeric), you need to enter the following information:

**Number of digits before point (0 to 14)**

Enter the number of digits you require before the decimal point.

In the example, the code has four digits, so enter 4.

**Number of digits after point (0 to 9)**

Enter a number to show how many places of decimals you want the program to work to.

In the example, the field is only to contain whole numbers, so enter 0 here.

Note: the sum of digits before and after the point should not be more than 14.

**Allow negative values?**

Type **Y** **RETURN** to allow numbers of less than 0  
**N** **RETURN** if they must be greater than 0, as in the example.

**Minimum value (up to 8 digits)**

Enter the smallest value you want in the field or press **RETURN** to leave the field blank.

In the example, press **RETURN**.

**Maximum value (up to 8 digits)**

Enter the largest value you want in the field or press **RETURN** to leave the field blank.

In the example, press **RETURN**.

**Delete protect?**

You can stop any record from being deleted if this field contains a value, by typing **Y RETURN** in this field. Type **N RETURN** or just press **RETURN** on its own if you do not want to protect the record from being deleted.

For example, if, within a file, a record has a field showing the balance of a customer's account, you could set this protection so that the account couldn't be closed while this field contained an entry, and money was still owing.

In the example, press **RETURN**.

Prompt **Details OK?**

Type **Y RETURN** to move to the next field  
**N RETURN** to go back and change what you've put in.

Complete this screen for every field in the file. It is essential that you have planned the entries carefully beforehand, as once a field is fully defined, it is not possible to go back and change it.

The fields for the Student file in the example are as follows:

---

Field number	1	2	3	4	5	6
Field name	Student code	Name	Address	Form number	Date of birth	Absence to date
Field type (A/N/D/R)	N	A	A	N	D	N
Number of characters		30	30			
Number of lines		1	5			
Number of digits before point	4			3		3
Number of digits after point	0			0		0
Allow negative values?	N			N		N
Minimum value	-			-		-
Maximum value	-			-		-
Delete protect?	N			N		N

---

When you've finished defining all the necessary fields for one file press **end** in place of the field name.

## Setting up the principal key

Next you need to set up the keys for the file you have defined. You generally make the first field in a file the principal key. This is the main key which will be used by the program to find records in a file.

There is more detail on defining keys in the next chapter. For the time being, follow these steps, to make only the first field a key, so that you can write an updating program and try out your system.

---

```

System number      20 School records
File number       1 Student file

Key number        1
Main key name     .....
Select field
Number of characters

```

---

Under the prompts is a list of all the fields (field number and description) in the file which you have just set up.

### Key number

This is given automatically by Nucleus.

### Main key name (up to 20 characters)

This will be used later when you select the reports you want to print.

In the example, enter `Student code`.

### Select field

Enter the field number. The field name will appear beside the number.

In the example, enter `1`.

Type `Y` to set up the `Student code` as the principal key. You are now asked for another key name. Just press **end**, as you only need to set up one key.

Next, Nucleus asks you to set up the details of another file. For now you only want to set up a single file, so press **end** and Nucleus will create the file to your specifications. You can add other files to your system later.



---

Program definition is complete

Is this to be a permanent or a temporary program (P/T/CAN)P

Generating file creation program

---

In this case Nucleus will automatically put in the P for a permanent file and call the program File creation.

---

Generating  
- please wait...  
Number of lines generated <number>

---

Updating files - please wait...

Mount School records program disc on drive B

---

Put your School records program disc into drive B and press **RETURN**. The program to create the Student file is put on the disc.

Message Updating files - please wait...

Mount Nucleus parameter file disc on drive B

Replace the School records program disc with your parameter disc and press **RETURN** to continue. You will return to the program menu.

---

Nucleus - Definition

PROGRAM MENU

1. Create Nucleus parameter file
  2. Create system definition
  3. Create file definition
  4. Create file linkage
  5. Print file definitions
  6. Create update program
-

## Writing a simple updating program

To try out your system you also need to use Nucleus to write the program which opens the filing drawer you've created and allows you to put data into it. This is called an updating program as it is used for changing and updating records as well as entering them for the first time.

Ignore the menu option for **Create file linkage** and **Print file definitions** at this stage. These are covered later in the guide.

Select **6** for **Create update program**.

Prompt **Select system (END)**

The available system numbers and names are displayed – in our case, number **20**.

Type **20** **RETURN**

The files and file numbers in this system are displayed for you to confirm that you have chosen the correct system.

Prompt **Select file (END)**

Type **1** **RETURN**

as this is the only file in your system.

The name and number of each field in that file is displayed.

---

Do you want to update all fields ? (Y/N/CAN)  
Select next field to be updated (END)

- 1 \*Student code
  - 2 Name
  - 3 Address
  - 4 Form number
  - 5 Date of birth
  - 6 Absence to date
-

When you come to write more sophisticated updating programs you will decide at this point which fields you want to update. The principal key has a \* beside it and will automatically be included. You cannot write an updating program without it.

At this stage, enter Y to update every field.

Prompt Details OK ? (Y/N/CAN)

Type Y **RETURN**

A \* will appear beside all the fields.

Prompt Details OK? (Y/N/CAN)

Confirm that the fields to be updated are correct by entering Y.

---

NO	FIELD DESCRIPTION	DATA NO OF		DATA HEADING	NEW SCREEN?	HEADING POSITION		DATA POSITION	
		LENGTH	LINES			LINE	COL	LINE	COL
1	Student code	4	1	Student code	N	5	5	5	26
2	Name	<b>30</b>	1	1 Name	N	7	3	7	26
3	Address	<b>30</b>	5	2 Address	N	8	3	8	26
4	Form number	3	1	3 Form number	N	13	3	13	26
5	Date of birth	8	1	4 Date of birth	N	14	3	14	26
6	Absence to date	3	1	5 Absence to date	N	15	3	15	26

---

Prompt Details OK ? (Y/N/CAN)

This gives you a chance to change the layout of the update program's screen display. We will cover this later, so type Y to use the layout Nucleus has defined.

Prompt Do you want a test display ? (Y/N/CAN) .

Enter Y to look at your update program's screen layout.

---

Select function (CRE/AME/DEL/REV/END) XXX

Student code	AAAA
1 Name	BBBBBBBBBBBBBBBBBBBBBBBBBBBBBBBB
2 Address	CCCCCCCCCCCCCCCCCCCCCCCCCCCCCCCC CCCCCCCCCCCCCCCCCCCCCCCCCCCCCCCC CCCCCCCCCCCCCCCCCCCCCCCCCCCCCCCC CCCCCCCCCCCCCCCCCCCCCCCCCCCCCCCC CCCCCCCCCCCCCCCCCCCCCCCCCCCCCCCC CCCCCCCCCCCCCCCCCCCCCCCCCCCCCCCC
3 Form number	DDD
4 Date of birth	EEEEEEEE
5 Absence to date	FFF

---

Prompt Is test display OK ? (Y/N/CAN)

Enter Y to confirm that the screen display is correct. N allows you to go back to the above screen to change the layout, if it is not right.

---

Program definition is complete...

Is this to be a permanent or temporary program ? (P/T/CAN).

Program description

---

Type **P RETURN**

to have the program stored permanently on your School records program disc.

Enter a description of the program in up to 30 characters. This will be used in the menu when you run it.

For the example, type `Student file update`.

The usual screen messages tell you that Nucleus is writing the program and updating files. Follow the prompts as before and you will return to the program menu.

You have now finished creating the example program – School records. To use it, leave Nucleus by pressing **RETURN** until you are back at the A> prompt.

## Using the School records program

You use the programs created by Nucleus in exactly the same way as Nucleus itself.

With the prompt **A>** displayed put the start-of-day disc into drive A.

Type **Start** **RETURN**

Enter the date and, when prompted, put the School records program disc into drive A and a blank formatted disc, labelled School records data disc, into drive B.

Press **RETURN** to continue.

The company menu will be displayed, as it was when you started running Nucleus itself and you select **1** as before.

---

### SYSTEM MENU

1. School records
  2. Change discs - other menus
- 

Type **1** **RETURN**

---

School records

### PROGRAM MENU

1. File creation
  2. Student file update
- 

This shows the programs you have created so far. The **File creation** program was created for you when you defined the files.

Select **1** from the menu for **File creation**, to run the program which sets up the files on the data disc.

Enter drive name for files (END).

(Valid drive names are A,B)

---

Type **B** **RETURN**

Prompt Is the files disc present on drive B  
(Y/N/CAN).

Check that your School records data disc is in drive B and type Y  
**RETURN**.

---

File name	CREATE ? (Y/N)
Student file	

---

Enter Y to create the file. As the file is created, the message  
File created is displayed on the right of the screen, and you will  
return to the program menu.

Type **2** **RETURN**

to run the School records update program and enter data to your  
Student file.

---

Select function (CRE/AME/DEL/REV/END) ...

Student code

- 1 Name
- 2 Address
- 3 Form number
- 4 Date of birth
- 5 Absence to date

---

Press **create**

and enter a few example names and addresses. When you are entering the names, type the surname first. This will allow you to sort the records alphabetically later.

When you've finished press **end** at the first field of a new record.

When you have done this, you can amend, delete or review the details until you're sure they're correct, and then press **end** to finish creating new records.

You have now created a very simple program and run it.

Now, leave the Student records system in the usual way, by pressing **RETURN** until the A> prompt appears.

The final stage in this example is to print a report showing the data you typed in.

## Printing a simple report

Start Nucleus running as before, but put the disc labelled Nucleus Reporting in drive A and your parameter file disc in drive B.

---

### SYSTEM MENU

1. Nucleus - Reporting
2. Change discs - other menus

---

Select 1 from the menu.

---

Nucleus - Reporting

### PROGRAM MENU

1. Create M/F print program
2. Create selected report program
3. Create label print program
4. Create letter program
5. Create document program

---

Select 1 from the menu.

Enter page size for report Standard  
Enter line size for report 132

Enter report headings

Line 1  
Line 2

---

### Enter page size for report

This shows the number of lines per page. The program automatically displays **Standard** which means 66 lines. To accept this figure in the example, press **RETURN**.

If you want to change the number of lines:

type      <new number> **RETURN**

### Enter line size for report

This shows the maximum number of characters per line. If you do not want to use 132 as the number of characters:

type      <number of characters> **RETURN**

To accept the number for the example, press **RETURN**.

### Enter report headings

You can enter two lines of heading of up to 40 characters each, to be printed at the top of all your reports.

For the example:

Type:      School records **RETURN**  
         Autumn term 1984 **RETURN**



When you have keyed in all the data and confirmed that it is correct, you will see:

prompt    **Select system (END)**

Choose the School records system by entering **20**.

Prompt    **Select file (END)**

Choose the file from which you want to take data by typing the file number – in this case **1**.

You have now fully defined your report-writing program. The usual screen messages will appear, and you should enter **P** to show that this is a permanent program, and then enter a program description, such as **Student report**.

Follow the prompts as you did earlier, when Nucleus was writing the updating program. The Student report program will then be added to the School records system.

To run the program, go back to the system menu by pressing **RETURN**.

When you ran your School records program, you went back to the **A>** prompt and started again using the start-of-day disc. In fact, a shorter route would be to select **2** from the system menu for **Change discs - other menus**.

Message    **Change program and data discs - 'ENTER'**

Put your School records program disc in drive A and the School records data disc on drive B and press **RETURN**.

Select **1** from the company menu.

---

SYSTEM MENU

1. School records
  2. Change discs - other menus
- 

Type        **1 RETURN**

School records

PROGRAM MENU

1. File creation
  2. Student file update
  3. Student report
- 

Select **3** from the menu.

---

Do you want to continue ? (Y/END) .

From Student code

to Student code

---

Enter Y to continue with the printout and type in the numbers of the first and last student codes that you want printed out. Pressing **RETURN** at each line will automatically give you the first and last student codes entered into the program.

When you have confirmed that the details are correct, the printout will begin automatically.

When printing has finished, you return to the School records program menu.

# 6 Planning keys and links

---

So far you have set up a very simple system, with a single file. This chapter explains how to identify keys and link files together. In chapter 7 you will set up another file in the School records system and put this theory into practice.

When you set up a system using Nucleus you need to store your information so that retrieval is as fast as possible. The essence of good system design is to store the information using as little space as you can. To help in this you can set up links between files which allow you access from one file to information stored in another.

This means that you can get at your store of information in many more ways than if you were using a filing cabinet. Nucleus gives you links between the cabinet drawers so that you can open one drawer and automatically look at or alter information in a folder in another drawer.

The links are used in four ways:

- to allow the person entering data to check against information stored in another file, by displaying it on the screen (called validation)
- to change fields in a second file automatically when data is entered to a linked file (called updating)
- to keep the contents of files to a minimum, making the whole system as fast as possible
- to take information from more than one file when you produce reports.

A company employee records system, for example, might have an employee file and a department file. Links between the files would allow you to:

- make sure employees are only given valid departments, using a code stored in the employee file, keeping this file small, but displaying the department name from the department file
- keep the total salary for a department up to date automatically by increasing it by the salary of new employees as their details are entered.

## Employee records system

## Employee file

Employee number	key
Name	
Address	
Date of birth	
Salary	
Department number	

— link —▷

## Department file

Department number	key
Department description	
Total department salaries	

## Deciding on the keys to use

When you use Nucleus you need to mark fields in your files to provide you with an index to your records. These index tabs are called keys. You can have several indexes for one file, allowing you to sort through the records in different ways. The program will flick through the tabs very quickly to find the record it needs.

In theory you could define up to five fields in a file as keys, but this would take up a lot of room and make the program work more slowly. In practice you would probably enter not more than two keys for each file, and usually only one. You usually make the first field in any file into a key, just as you did for the Student file in chapter 5.

It is the keys you set up which allow you to make links between files.

The key in a file will give you access to information in all the fields in that file. In a complex system you will have many files with several of these links.

## Using links

When you've established your keys you need to decide:

- which files you want to link together
- what the links will be used for; usually updating or validation
- which fields you will use to make the links
- which direction the links should work in.

The direction the link is to work in is important. You always link towards the file you want to get information from in validation, or towards the file you want to update automatically. You link from the primary file towards the secondary file.

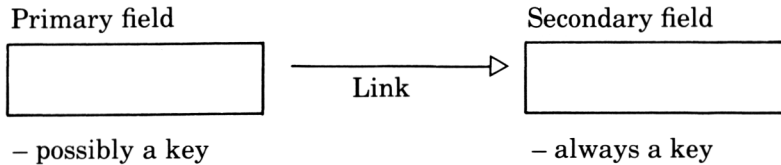

The primary end of the link can be any field – whether it is a key or not. The secondary end of a link, however, must always be a key. Nucleus will not allow you to link towards a field which is not a key.

If you want a link to work in both directions you must set it up twice; once in one direction and once in the other.

You can also use links to store short forms of data in a file, rather than long descriptions. You would link this file to one containing the full descriptions and the specification of the correct form of the abbreviation. Then when you enter data you would validate against the second file each time you typed in the abbreviation.

This cuts down on the time taken to type information in and the disc space needed for that file. For example, you can set up codes for specific information rather than entering it in full, such as

G/A/P    for good, average or poor performance  
 F        for French, and so on.

You don't have to set up all your links at one time, but can add extra ones as you need them.

For every file in the system you are designing you must:

- define all the fields in the file
- specify all the keys in the file
- make sure that the fields you want to link are specified identically in all files
- make sure you always set the same specification for numeric fields you want to link: you can't link a field set for six digits before the decimal point to one set for only two
- make sure your linked fields have the same restrictions placed on them in both files (such as maximum and minimum values)

## Using keys for sorting

Keys are also used for speeding up the sorting of records stored in your files. If, for example, you wanted to sort your students alphabetically you could make the name field in the Student file a key.

You only need to do this if you intend to sort in this way very often. When you write reporting programs you can specify the sorting methods to be on any field, whether the field is a key or not.

## Master and transaction files

There are two types of file used by Nucleus, master and transaction files.

The Student file which you set up in the last chapter is a master file. These represent a collection of individual items, such as employees, cars for hire or bank accounts.

Master files are files containing several records, each with an index tab or key. They store basic information about, for example, customers or suppliers, or the books in a library.

Your address book or list of people's telephone numbers is a master file.

Every time you put information into one of the records in a master file, you will write over what is already there, for example, you could change someone's address in your address book. You can also add new records, such as new names and addresses.

The other type of file is a transaction file, which holds information on a sequence of events, for example, employees' absences, car hire bookings or bank statements.

A transaction file has a number of transactions and you can add records to it, without changing what is already there. This means that many records may have the same key. Each time you enter another transaction to this file, the file is added to. This doesn't change any of the information already in the file.

For a link between files to work, it has to be able to identify a unique record. If not, there would be confusion over which record to update or take validation details from. Therefore, you can only link to a master file.

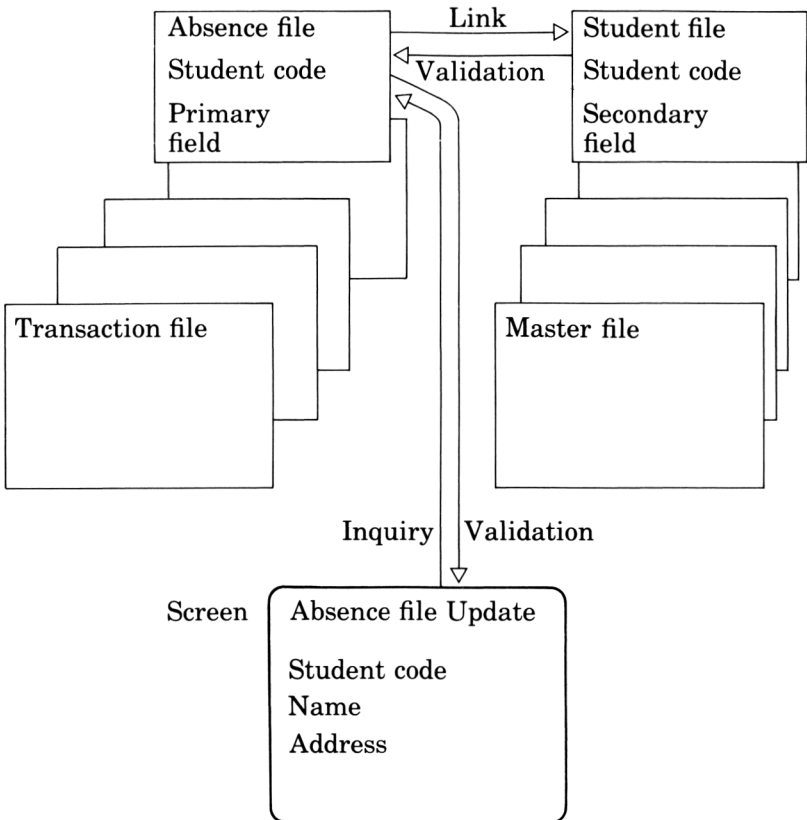

Usually Nucleus systems have a few master files holding the basic information, being used by several transaction files. This is illustrated in the diagram above.

## Designing an updating program

Every file must have an updating program as, without it, you cannot put information into the file. This is the program which opens the drawer of the filing cabinet so that you can put records into it. You will use the updating program to enter data to the files, and to amend and update information already stored.

The updating programs you design control:

- the way data is entered
- checking of linked fields in other files as you enter data
- automatic updating of fields in linked files.

Your updating program supplies all the prompts needed to help the user enter the correct information to your records. Bear this in mind when you are setting up your systems, as the way you design the program and describe the fields will affect how easy it is to use.

You could, for instance, include in your field description an indication of how the data is to be typed in, such as:

Date (DDMMYY)  
Staff no. (6 digits)  
Performance (G/A/P)

To update fields automatically, you set up calculations. Then when you change the information in one field, the program uses this value to calculate the corresponding change to a field in another file.

For example, if you type into the Absence file the fact that a student has been absent for five days, you would automatically update the last field in the Student file (Absence to date) by adding five days to the figure already in the Absence to date field. This would give the total absence to date.

The next chapter continues with the School records example, showing how this theory works in practice.



# 7 Setting up a system with linked files

---

In chapter 6 you set up a single file for the School records system, with one key, the Student code. To practise using keys and links, work through the next stage of the example, in which you set up a second file in the system so that you can link one to another.

The Student file you set up before was a master file. Now you can set up a transaction file, the Absence file, which has details of when students' have been absent and for how long.

If you want to develop the system you can then set up a file for staff details, a file for each form and several more, such as one for subjects taught.

In our School records example you will set up the following keys and links.

## Student File

- 1 Student code      key
- 2 Name
- 3 Address
- 4 Form number
- 5 Date of birth
- 6 Absence to date

## Absence file

- 1 Student code      key
- 2 Date of absence
- 3 Reason given
- 4 Length of absence

Student file

Student code	Key
Name	
Address	
Form number	
Date of birth	
Absence to date	

← Link  
for  
validation  
and  
updating

Absence file

Student code	Key
Date of absence	
Reason given	
Length of absence	

This allows you to:

- store the names and full addresses of the students in one file and set up another file for details of absence without including the names and addresses again
- validate the student's name, by showing it on the screen when you enter absence details to the Absence file
- update automatically the figure for absence in field 6 (Absence to date) of the Student file whenever a new entry is made in field 4 (length of absence) of the Absence file.

With the Nucleus Definition disc in drive A and the parameter disc in drive B, select **3** for **Create file definition** from the Nucleus Definition program menu.

Select the School records system, and type in the details for the Absence file in the same way as you did for the Student file. The details of the fields are given below. If you're not sure how to do this look, back at Chapter 6. Remember to type **T** for transaction file after the prompt **File type (M/T)**.

## Absence file – transaction file

---

Field number	1	2	3	4
Field name	Student code	Date of absence	Reason given	Length of absence
Field type (A/N/D/R)	N	D	A	N
Number of characters			40	
Number of lines			3	
Number of digits before point	4			3
Number of digits after point	0			0
Allow negative values?	N			N
Minimum value	-			-
Maximum value	-			-
Delete protect?	N			N

---

When you have finished defining the fields press **end** in the place of the field name.

---

```

System number      20 School records
File number        2 Absence file

Key number         1
Main key name      .....
Select field
Number of characters
    
```

---

Under the prompts is a list of all the fields in the file you have just put in, for you to select from.

### Key number

This is given automatically by Nucleus.

### Main key name (up to 20 characters)

This will be used later when you select the reports you want to print.

Type Student code **RETURN**

### Select field

Enter the field number. The name will then appear beside it.

Type 1 **RETURN**

### Number of characters?

Enter the number of characters you want the program to sort by. For example, if you were going to sort alphabetically, you would do so using only the first 4 characters of a name which would be quicker than using the whole name.

For numeric fields, as in the example, you will not have to reply to this prompt.

When you've entered the information for the key in your file, press **end** in the space for the main key name. You could then enter the details for another file, if you wanted to.

In the example, there are only two files (the Student file and Absence file), so you would press **end** in the space for the file name of a new file, to indicate that you have finished the file definition.

## Linking files together

Option 4 on the Nucleus Definition menu sets up the links between your files.

When making these links, you enter the details for the primary field first, then the secondary field.

First, you need to set the Student code in the Absence file as the primary field, so that you can validate each code you enter against the Student file. This link can also be used to update automatically the field for Absence to date (field 6) in the Student file, each time you make an entry in the last field in the Absence file (Length of absence).

The Student file is the secondary end of the link as this is the file which will be validated against and updated. You have to use the Student code as the secondary field, as this is the only field in the Student file which is a key.

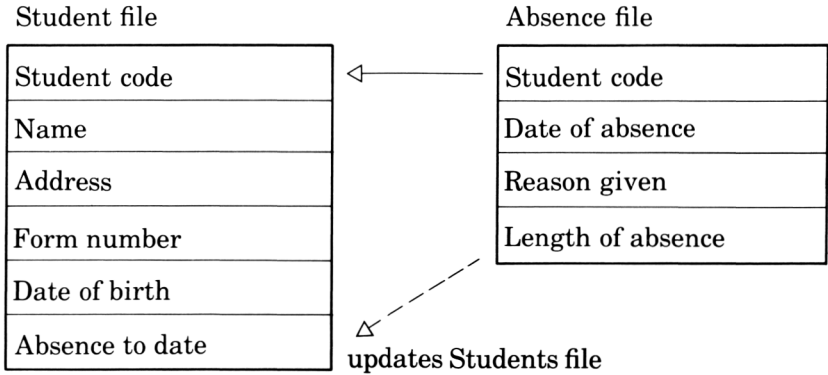

Nucleus - Definition

PROGRAM MENU

1. Create Nucleus parameter file
2. Create system definition
3. Create file definition
4. Create file linkage
5. Print file definitions
6. Create update program

Select 4 from the menu.

Do you want to continue ? (Y/N/END)	
Select primary details(CAN)	Select secondary details(CAN)
System name	System name
File name	File name
Field name	Key name

### System name

Enter the number of the system you want at the primary end of the link, in this case, 20. The system name then appears. When you've confirmed that this is correct, all the file names and numbers are displayed.

### File name

Enter the number of the file you want, in this case 2 for Absence file. When you've confirmed that the file is correct, the fields in it are shown with their numbers.

### Field name

Enter the number of the field you want to use as the primary key. In the example this is field 1.

Next set up the Student code field in the Student file as the secondary field. You made it a key in chapter 5.

Prompt:

Type:

System name

20 RETURN

File name

1 RETURN

Key name

1 RETURN

Your linked fields must be compatible; you cannot link a number field to a letter field or a date to either. When you key in the information for the secondary field, only keys will be displayed as you can only choose a key at this stage.

Message File linkage definition is complete...  
Details OK? (Y/N/CAN)

Type

Y RETURN

to record the linkage

N RETURN

to enter the details again

cancel

to cancel the operation.

When you've finished:

Press **end** at the Do you want to continue? prompt.

## Writing more complex updating programs

Now you are ready to test the link you've set up by producing an updating program in which some of the fields in a file are updated automatically and you validate records as you enter the information.

You need to write at least one updating program for each file in the system. You have already produced a simple updating program which allows you to put information into the Student file manually, without any validation or automatic updating.

In fact it would be much more sensible to update the field for Absence to date in the Student file automatically each time an entry was made in the Length of absence field of the Absence file.

This would have the added advantage that no-one could alter the entry in this field manually. You can also protect your records using passwords, as explained in the chapter **Using passwords** later in the guide.

This section explains how to produce:

- an updating program for the Student file which updates all the fields manually except field 6, Absence to date
- an updating program for the Absence file which allows validation against the Student file to check the student's name and form number each time you enter a student code, and also updates field 6 (Absence to date) of the Student file automatically.

## Updating selected fields

Select 6 from the menu for Create update program.

Select the system you want to work on by entering the system number, 20.

Prompt    Select file (END)

Type      1 **RETURN**

The name and number of each field in that file is displayed.

---

```

Do you want to update all fields ? (Y/N/CAN)

Select next field to be updated (END)

NO DESCRIPTION UPDATE? NO DESCRIPTION UPDATE? NO DESCRIPTION UPDATE?
1* Student code
2 Name
3 Address
4 Form number
5 Date of birth
6 Absence to date

```

---

Prompt    Do you want to update all fields ?  
(Y/N/CAN)

In the example, type N **RETURN**.

This tells Nucleus that you don't want to update all of the fields manually. In the example, you would update all the fields, except field 6 which will be automatically updated from the Absence file.

The principal key has a \* beside it and will automatically be included. You cannot write an updating program without it.

Prompt `Select next field to be updated (END)`

Enter 2, 3, 4 and 5, each followed by **RETURN**, to update the Name, Address, Form number and Date of birth fields manually, and then press **end**.

Note: you will not be asked about validating or updating linked files as the link goes into the Student file – it is the secondary end of the link.

---

		DATA NO OF		HEADING DATA		
NO FIELD DESCRIPTION LENGTH LINES DATA HEADING SCREEN? LINE COL LINE						
COL						

---

The fields and their details will be listed below the headings.

This allows you to look at the way your program will look on the screen when it is run and gives you a chance to change the layout of the update program's screen display if you want.

You can change the following information:

**DATA HEADING**

This is the name of the field.

**NEW SCREEN?**

You can make some of the fields start on a new screen if this makes data entry easier.



**HEADING POSITION LINE COL**

This shows the position on the screen at which the heading will appear as prompts for the data to be typed in.

**DATA POSITION LINE COL**

This shows the position of the data.

Prompt **Details OK? (Y/N/CAN)**

To practise changing the display you need to see an example of how the screen would look. Type **Y** **RETURN** and you will see

prompt **Do you want a test display ? (Y/N/CAN) .**

Enter **Y** to look at the your program's screen layout.

---

```

Select function (CRE/AME/DEL/REV/END) XXX
Student code          AAAA
1 Name                BBBBBBBBBBBBBBBBBBBBBBBBBBBBBBBB
2 Address             CCCCCCCCCCCCCCCCCCCCCCCCCCCCCCCC
                    CCCCCCCCCCCCCCCCCCCCCCCCCCCCCCCC
                    CCCCCCCCCCCCCCCCCCCCCCCCCCCCCCCC
                    CCCCCCCCCCCCCCCCCCCCCCCCCCCCCCCC
                    CCCCCCCCCCCCCCCCCCCCCCCCCCCCCCCC
3 Form number         DDD
4 Date of birth       EEEEEEEE

```

---

The Absence to date field will not be included in the display as this will not appear on the screen when you run the program.

Prompt **Is test display OK ? (Y/N/CAN)**

Enter **N** to go back and change the layout.

Prompt **Details OK ? (Y/N/CAN)**

Enter **N** to change the layout.

Prompt **Input field number to be amended (ENTER)**

You could, for example, change the data headings to assist the person entering data, and space out the fields to make the display easier to read.

Enter 2 to change the display of the Name field and type over the entries at the position of the cursor. You could type **Name (in full)** and press **RETURN** to leave the other fields as they are. If you change the data positions you must remember to move all the subsequent fields down the screen as well.

You can edit the fields as often as you like, pressing **RETURN** on its own at the prompt to go on to another test display.

When you've finished, ask for another test display to see how this has changed.

When you accept the details you will see:

---

Program definition is complete...

Is this to be a permanent or temporary program ? (P/T/CAN).

Program description

---

Type **P** **RETURN**

to have the program stored permanently.

Enter a description of the program in up to 30 characters. This will be used in the menu when you run it. In the example, enter **P** for a permanent program and the description **Student file update 2**, as you have already created one Student file update program in chapter 5.

The usual screen messages tell you that Nucleus is writing the program and updating files. Follow the prompts as before to store the program on your School records program disc.

When you've replaced the parameter disc and pressed **RETURN** you will return to the main Nucleus Definition menu.

## Including validation and automatic updates

For the example system to work, you also write an updating program for the Absence file, a transaction file, which allows you to check that you are entering details for the right student, and tells the system to update field 6 of the Student file automatically.

Go through the following steps.

Select **6** from the Nucleus Definition program menu.

Select system **20** and the Absence file, file **2**.

Enter **Y** to show that you want to update all fields.

---

```
Student code   is linked to School records   Student file
Do you want to validate this field?
Select next field to be displayed (END)
```

---

Enter **Y** to confirm that you want to validate against fields in the Student file.

Select the fields you want to validate against, typing **2** to display the student's name each time you enter a student code, and **4** to check the form number.

Press **end** and you will return to the display of the Absence file fields which will all be marked with a **\***, to show that all the fields will be updated manually.

Prompt **Details OK? (Y/N/CAN)**

Type **Y** **RETURN** to confirm that the details are correct.

You are now given the chance to look at the screen display your program will have, and change it as before if you want to.

When you are happy with the display, accept the details.

---

Do you want to update any information in linked files? (Y/N/CAN).

Field name		System name	File name
Student code	is linked to	School records	Student file

---

Type **Y RETURN**

The screen shows that the Student code is linked to the Student file.

Prompt Do you want to update this file?

Type **Y RETURN**

Prompt Select next field to be updated

Enter 6 to update the Absence to date field automatically.

---

System name	School record
File name	Student file
Field name	Absence to date

Enter amount of update (e.g. +A\*(B+1)) (END)

\*\*\*Mathematical functions available\*\*\*

+Addition	*Multiplication	^Exponentiation (Parentheses can be
-Subtraction	/Division	used in the formula)

A Length of absence

---

The fields from the Absence file which are suitable to be used for the updating (that is they are defined in the same way as the field to be updated) are displayed.

You can arrange to update field 6 in the Student file every time you make an entry to field 4 (Length of absence) in the Absence file, by replacing the entry in the Student file with the existing value plus the number of days you type in for the next period of absence.

The formula is the relationship between the entry you're making and the number already in the linked field.

For the example, type +A **RETURN**.

When you've finished setting up the formula the complete list of fields in the file you're working on is displayed for you to choose the next one to update.

In our example, you only want to update one field automatically, so press **end** to generate the program.

Make the program a permanent one, called **Absence file update**.

## Running your new programs

Now you are ready to try out your updating program.

Press **RETURN** to go back to the system menu and select 2 to change discs.

Put your new program disc into drive A and a data disc in drive B to save the information typed into the files.

---

School records

PROGRAM MENU

1. File creation
  2. Student file update
  3. Student report
  4. Student file update 2
  5. Absence file update
- 

The screen displays all the programs you have created.

You no longer need the first Student file update program you created and so you can remove it from the menu.

Press **amend**

Prompt **Select number**

Enter the number of the option you want to remove, in this case, 2, and press **delete** to erase it. Then press **end**.

There is more information on the use of **amend** in the section **Amending menus** later in this guide.

Next, you need to create the Absence file on your School records program disc so that it is ready to receive the data when it is typed in.

If you have arranged for one of your files to be checked against another during updating, you will need to put some data into this file first. Otherwise, when you try to run the other updating program there will be no data to display for validation and the program will not work.

Select 1 from the menu for **File creation**, to run the program which sets up the files on the data disc. This is the program which Nucleus created first, called **File creation**.

Enter drive name for files (END).

(Valid drive names are A,B)

Type **B RETURN**

Prompt **Is the files disc present on drive B (Y/N/CAN).**

Check that your School records data disc (called the files disc on the screen) is in drive B and type **Y RETURN**.

File name	CREATE ? (Y/N)
Student file	.
Absence file	.

You created the Student file in Chapter 5, but the screen still shows it, so enter **N**. (If you type **Y** the system will tell you that the file already exists.) Enter **Y** to create the Absence file. When the file has been created you will return to the menu.

---

School records

PROGRAM MENU

1. File creation
  2. Student report
  3. Student file update 2
  4. Absence file update
- 

Select 4 for Absence file update.

Prompt CRE/AME/DEL/REV/END

Press **create**

Prompt Student code:

When you enter the code you will see the corresponding student's name and form number displayed.

Try entering some data to each of the files, by selecting the corresponding updating program from the menu and pressing **create**, and print out the simple report so that you can see the results. When you enter extra days' absence to the Absence file you will find that field 6 of the corresponding Student file records are updated by the same amount.

To check what is in the records of the Absence file, select 4 for the Absence file update program, press **review** and enter a student code. The entries are then displayed for that code by pressing **RETURN** without entering another code.

To check the entries in the student file, select 3 for Student file update program 2, press **review** and enter a student code.

# 8 Planning reports, letters and other documents

---

You can use Nucleus to design programs that will print out a variety of reports, using data stored in your record systems. This allows you to produce standard letters, financial statements, such as profit and loss accounts, and to print invoices and labels.

This is the way you retrieve from the system the information you enter using your updating programs.

You design these programs using the parts of Nucleus shown below to specify which data to use and where it is to come from, and to define the nature of your printout.

---

<b>Program</b>	<b>Layout of text</b>	<b>Applications</b>
Master file print	Vertical columns under headings	Printing contents of a master file
Selected report	Vertical columns under headings	Tables
Label print	Label format	Printing address labels
Letter	Text with data in position	Standard letters Financial reports
Document	Vertical and horizontal format	Forms, statements Invoices

---



Before you set up the programs on the computer you need to plan:

- which of the records in any file you want printed out, for example, all students with names beginning with A
- the order in which they should be printed, for example, in alphabetical order
- whether you want to print the actual values stored in your files, or whether the program should calculate values based on those in the files and print the results instead, for example, converting a number into a percentage.

## Choosing the records to be printed and the printing order

When you design your reports you can choose which records you want printed and in what order. You select the records by making up an expression using the following symbols:

=	equal to
<	less than
<=	less than or equal to
>	greater than
>=	greater than or equal to
<>	not equal to
&	and
!	or

You can use these for alphanumeric and numeric fields.

For example:

=A	means print all the records whose initial letter is A
<100	means print records where the field your specifying has a value less than 100
=>100&=<1000	means print records where the value is between 100 and 1000.

You can then choose the order in which the records are printed as ascending or descending. In an alphanumeric field ascending order starts at the earliest letter in the alphabet, while descending order starts with the latest letter.

Similarly, for numeric fields you can either print the record with the lowest value first and work upwards, or print from the highest value first and work downwards.

You can specify up to five levels of sorting. For example, you could print your records in alphabetical order, producing separate lists for each form.

You can also have totals calculated and printed at various stages in your report if you want to.

In chapter 10 we set up a label-printing program for the names and addresses of the students, selecting to print only those whose student codes are above a specified number, and printing in ascending alphabetical order.

## Printing calculated values

To calculate the values to be printed in your reports, you select what is called a computed field.

The idea of a computed field appears frequently in this part of Nucleus. It allows you to print not just a field itself, but a value derived from the field.

You can only choose numeric fields and fields you've already selected for printing to use as computed fields.

Each field that you select for printing is automatically labelled alphabetically and the fields with their corresponding letters are displayed. You then construct a mathematical formula, using these letters, to tell Nucleus how to do the calculation.

The symbols you are allowed, which are displayed on the screen, are:

=	for addition
-	for subtraction
*	for multiplication
^	for exponentiation
/	for division.

In chapter 9 there is an example of producing a report using a computed field from the School records files. This is an absence report for each form, in which the days each student is present are calculated from the figure for Absence to date, field 6 of the Student file.

## **Designing a report-writing program**

You can use the Nucleus report-writing program to produce special reports from data entered to an accounting package like Accountant, or for new systems you've created with the Nucleus Definition program.

Before you start, design your reports carefully, planning:

- what data is to be included
- where it will come from
- how much space it will take up
- how long the pages will be
- how wide the pages will be
- what headings you want.

In chapters 9 and 10 we describe how to set up selected reports and label prints, illustrating how to select which information you want to use and what order you want the records printed in.

Chapters 11 and 12 explain how to produce letter and document programs.

## **Printing a specially-designed report**

If the Nucleus master file print program doesn't suit your needs, you can set up your own report-writing program using the second option on the menu for **Create selected report program**.

When you use this part of Nucleus you go through the following steps.

- 1 Set the page width and type in a title to be printed on every report produced using this program.
- 2 Choose the system and file you want to take information from.
- 3 Choose which fields you want printed in your report. Where a field has been linked to a field in another file, the fields in the second file are displayed and you can choose which of those you want to print as well.

- 4 Choose which records you want to print and in what order.
- 5 Decide whether you want totals calculated and printed and page breaks to be put in.

When you plan and design your report, you need to work out all these choices so that you can enter them in response to the screen prompts.

You can sort by fields which were not defined as a key when the file was structured, and fields which you have not selected for printing.

There is an example of how to set up a selected report in the next chapter.

## **Writing a label-printing program**

This part of Nucleus is very similar to the selected report generator and you make many of the same decisions. With it you can write a program to print labels of whatever size you like, in whatever order you wish, using information taken from your data files.

The steps you have to go through are as follows.

- 1 Decide how big the labels will be and how many will fit across your page. You must bear in mind the number of characters there will be in the lines to be printed to make sure they will fit on the label.
- 2 Choose the system you are going to take your data from and the file within that system.
- 3 Choose the fields which hold the information to be printed on the labels. The screen will display fields in linked files for you to choose from as well.
- 4 Check the details and do a test print.
- 5 Choose the order in which the labels are to be printed.
- 6 Choose the records you want to print and those which will be ignored.

There is an example for you to try out in chapter 10.

## Designing a letter-writing program

With this part of the program, you can type out the text of a standard letter and design a program to print out copies of it which include information stored in your records. This is very useful for merging names and addresses with a standard letter.

For example, you could send a letter to the customers who owe you money (and therefore have a debit balance in their account), printing the letters in alphabetical order, or you could send a letter to all those who owe you more than £1000 and a different letter to those who owe less than this.

Your letter-writing programs must use master files as their source of information. You can then print a single copy of the text for each record you select to take information from.

Part of the letter-writing program acts rather like a word processor. You can type in text and edit it on the screen using letter keys with **SHIFT**, **DELETE**, **TAB**, **RETURN** and the cursor keys. You set up these computer keys using the first option on the letter-writing menu, Amend letter editor parameters.

In chapter 11 there is an example of how to set up a letter-writing program.

## Designing a document-writing program

With this part of the program you can type out the text of a standard document, such as an invoice, and design a program to print out copies which incorporate data stored in your records.

When you set up a document-writing program, the main file you extract data from must be a transaction file. You can use master file information in your document headings, for example, but as soon as you specify a transaction file field the program will recognise this as repeated information and will print all the transactions you select.

This is very useful for extracting information you have recorded using Accountant. You also select which fields you do or don't want to print.

In chapter 12 there is an example of an Absence report set up using the document-writing program.

## **Producing reports from Accountant files**

If you want to produce reports from your Accountant records, the files have already been established by the accounting software and cannot be changed. You design and set up your reports in the same way as you would any other report, letter or document, but with your working copy of the parameter disc that came with your system in drive B.

This contains details of the file structures for Accountant. You will select the Nominal ledger system, which will have a number less than 20 on the screen, and choose the files which contain the data you want to extract.

When you run the program you have designed, you will need to put the new program disc in drive A and your Accountant data disc in drive B or you can transfer the report program on to your Accountant program disc and add it to the nominal ledger menu options, using the amend facilities described in chapter 14.

If you are producing letters or documents from Accountant files you will find your computer keys have already been set up on the parameter disc.

# 9 Producing a selected report-writing program

---

This chapter goes through an example of how to set up a selected report based on the School records system. You have already produced the simplest type of report — a master file print — in chapter 5.

To set up the report-writing program put your start-of-day disc in drive A and enter the date as described in chapter 3.

Then put your Nucleus Reporting disc in drive A and the parameter file disc you've been using with the School records program in drive B.

---

## SYSTEM MENU

1. Nucleus - Reporting
  2. Change discs - other menus
- 

Select 1 for Nucleus - Reporting.

---

Nucleus - Reporting

## PROGRAM MENU

1. Create M/F print program
  2. Create selected report program
  3. Create label print program
  4. Create letter program
  5. Create document program
- 

Using the School records system, you can print an attendance report for each form, calculating how many days each student was present during a term. The program would take data from the Student file, printing:

- the Student code
- that student's Name
- the Form number
- the Absence to date
- the days present.

These could be sorted by Form number, so that you print out a separate report for each form.

Select 2 from the Nucleus Reporting menu for Create selected report.

---

Enter page size for report Standard  
Enter line size for report 132

Enter report headings

Line 1

Line 2

---

Enter page size for report

The number of lines per page is set to the standard length of 66 lines.

Enter line size for report

Leave this as 132 if your printer is using wide computer paper or the printer is printing in condensed mode (17cpi). If it is not, make the line length shorter.

Press **RETURN**

Enter report headings

You can use two heading lines with up to 40 characters in each.

Type Form attendance report **RETURN**  
Autumn term **RETURN**

These will be centred automatically and printed at the top of every new page.

Now select your system and the file within the system that you want to print from.

Type 20 **RETURN**  
1 **RETURN**



Prompt Select next field to be printed (END)

All the fields in the file you've chosen are displayed under the prompt, and you should enter and confirm the field number for each field you want printed, including the computed field, to calculate days present.

Enter fields 1, 2, 4, 6, and 99.

If you choose a field at the primary end of a link the screen will display all the fields in the linked file so that you can print from there as well.

In the example, the Student code is at the secondary end of a link so you will not see a display of fields in a linked file.

The fields you choose are marked with an \* on the screen when the list is next displayed.

## Using a computed field

---

```

Computed field description (END)      .....
Number of digits before point
Number of digits after point
Computed field formula E.G. A*(10+B)
*** Mathematical functions available ***
+ Addition      * Multiplication  ^ Exponentiation (Parentheses can be
- Subtraction / Division                used in the formula)

A Student code
B Form number
C Absence to date

```

---

Next, fill in the name you want given to the computed field and how it is to be calculated.

If the total number of school days in the Autumn term was 50 the days present would be 50 minus the figure for Absence to date.

In the example, enter:

```
prompt:                                     type:
Computed field description                 Days present RETURN
Number of digits before point             2 RETURN
Number of digits after point              0 RETURN
Computed field formula                     50-C RETURN
```

You can only use numeric fields to construct the formula.

When you have selected all your fields press **end** at the Select next field to be printed prompt.

## Doing a test print

The screen will now display the fields you've selected:

---

NO	FIELD DESCRIPTION	DATA		PRINT HEADING1	PRINT HEADING2	SPACES	NEW
		LENGTH				BEFORE	
1	Student code	4	Student	code	0	1	Y
2	Name	30		Name	1	1	N
3	Form number	3	Form	number	1	1	N
4	Absence to date	3	Absence	to date	1	1	N
5	Days present	3	Days	present	1	1	N

---

Check that the fields are correct and confirm them, using Y.

Prompt Do you want a test print ? (Y/N/CAN)

It is a good idea to do a test print so that you can see the spacing on your report and whether it will look satisfactory.

Check that the printer is ready and type Y. The test print will be carried out using fictitious characters so that you can see what the report will look like.

Prompt Is test print OK? (Y/N/CAN)

Your report will probably seem rather squashed. You can space out the columns by editing the screen to leave more space.

The program automatically splits headings of more than one word over two lines. It also puts one character space between each field.

If you want to change the headings enter **N** twice, and then edit or abbreviate the headings as necessary.

If you want to alter the spaces between the printed columns, change the numbers under the heading **SPACES BEFORE FIELD**.

You will then be able to do another test print to make sure that the new print format is satisfactory.

When you have confirmed that the test print is right, you move to the following stage.

## Printing order

Having selected the fields to be printed in your report, you can decide which order you want them to be shown in.

---

In which order is report to be printed ? ...

- 1 Student code
- 99 Other

---

Choose the order in which you want the report to be printed.

For the example, choose alphabetically by form, using the Name and Form number fields.

Type **99** **RETURN**

and the screen displays all the fields in the file for you to choose from for your sort.

If you are sorting alphabetically you can speed up the process by choosing only to sort by the first three or four letters of the name rather than the whole name.

The screen displays the field description.

In the example, enter 4 for Form number, followed by A to print in ascending order. Then enter 2, for Name and specify that the sort should be based on three characters in ascending order.

You can use five different sorts.

When you've finished, press **end** and the screen will display the sorting details you set up.

---

```

SORT DETAILS ...

NO  FIELD DESCRIPTION  DIRECTION  CHARACTERS
1   Form number       Ascending   3
2   Name              Ascending   3

```

---

When you are happy with the way the data will be sorted:

type **YRETURN** to confirm that it is correct.

You then go to the next screen.

---

```

Do you want to print all records ? (Y/N) .

Selection expression (END)
(More than one expression can be entered on each line)
(Parentheses can be used) Example:- A=1 & B<(C+D)*1.5
*** Symbols available ***
= Equal to < Less than <= Less than or equal to & And
<> Not equal to > Greater than >= Greater than or equal to ! Or

```

---

For the example, enter Y to print all records.

The next chapter illustrates how to select only some of the records for a label print.

Finally, you can specify where you want your program to calculate and print totals and where you want a report to start a new page.

---

Do you want totals or a new page on change of a key ?

No key name      New page ?    Totals ?    Total description

1    Form number

2    Name

99   Grand totals

---

Beneath this display is a list of the keys you've specified with the option 99 for **Grand totals**.

The Form absence report doesn't need totals, but it would be useful to start a new page with each new form. So, type **Y** to the **Do you want totals or a new page on change of a key ?** prompt.

To set the page break, type **Y** under the **New page** heading for Form number, and **N** in all the other fields.

The description is the text next to the total on the printed report.

When you've finished, confirm that the details are correct. You are now ready to generate the program, as before on your School records program disc.

Make the program permanent and enter **Form attendance report** as the description.

# 10 Producing a label-printing program

This chapter explains how to produce labels using the example of printing labels with the names and addresses of each student whose student code is greater than 1000, from the School records system.

With the following menu displayed:

---

Nucleus - Reporting	PROGRAM MENU
	1. Create M/F print program
	2. Create selected report program
	3. Create label print program
	4. Create letter program
	5. Create document program

---

select 3 for Create label print program.

---

Enter label description .....

Enter number of labels across page

Enter the width of one label - inches Tenths of an inch

Enter the height of one label - inches Sixths of an inch

Note.

If the labels are more than one across - the width of one label should be measured from the left hand edge of one label and the left hand edge of the next label.

The height of one label should be measured from the top of one label to the top of the next label.

---

Enter label description (up to 30 characters)

Enter a description for the label, for example, Student addresses.

Enter number of labels across page  
(between 1 and 9)

Enter the number you require, say 1.

**Enter the width of one label**

Type in the width you want for the label in inches and tenths of an inch, referring to the diagram below. In the example, enter 3 inches and 5 tenths.

**Enter the height of one label**

Type in the height of the label in inches and sixths of an inch. Enter 1 inch and 3 sixths.

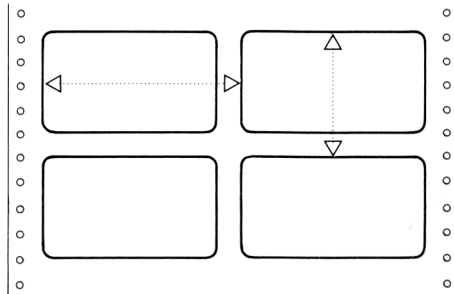

Next, select the system and file you are going to draw data from.

In the example, these are the School records system and the Student file.

Prompt `Select next field to be printed (END)`

Enter fields 2 and 3 and press **end**.

If you choose a field linked to another file, the fields in the second file are displayed for you to have printed as well.

If you select a field which is too long for the label size you've specified, you will see:

message `FIELD WIDTH EXCEEDS LABEL WIDTH`

and you must press **cancel** and set the label width again.

The fields you've selected will be displayed. Check that the details are correct and do a test print, if necessary, to see how the data will appear on your labels.

## Specifying the print order

You have the same options as before for the order of print:

- Student code
- 99 other

Select **99** and print your labels in ascending alphabetical order by name. The Name field is number 2 and you should use three characters of the name.

Press **end** and the sort details will be displayed for you to confirm.

## Selecting the data to be printed

Next, you can choose which labels you want printed.

---

```
Do you want to print all records ? (Y/N) .
```

```
Selection expression (END)
```

```
(More than one expression can be entered on each line)
```

```
(Parentheses can be used) Example:- A=1 & B<(C+D)*1.5
```

```
*** Symbols available ***
```

```
= Equal to < Less than <= Less than or equal to & And
```

```
<> Not equal to > Greater than >= Greater than or equal to ! Or
```

---

Type **NRETURN**

to show that you don't want to print all the records.

### Selection expression

You can specify which records you want included and which should be ignored by devising an expression, made up of the displayed symbols and the letters corresponding to the fields in the file. This expression is then used as the factor for selection. The symbols are shown on the screen.

For the example:

type **A>1000**

to print the records for all student's whose Student codes are higher than 1000.



You can enter up to five such expressions for any one report.

You must enter the expression in precisely the correct form or you will get the message:

Invalid expression

Press **end**.

When you've confirmed that these details are correct, you have fully defined your label-printing program. Generate it on your School records program disc as before, making it a permanent program and calling it **Student addresses**.

# 11 Producing a letter-writing program

---

This chapter explains how to produce a letter-writing program.

The whole chapter is written as an example for you to try out, and will tell you, using our School records example, how to send a letter to all sixth-form students inviting them to a party.

With the following menu displayed:

---

```
Nucleus - Reporting          PROGRAM MENU
                               1. Create M/F print program
                               2. Create selected report program
                               3. Create label print program
                               4. Create letter program
                               5. Create document program
```

---

Select 4 from the menu.

---

```
Select number (END) .
    1 Amend letter editor parameters
    2 Create letter program
    3 Create/amend letter text
    4 Delete letter
```

---

Option 1 sets up the text editor part of Nucleus for the keyboard you are using. If you are using the Nucleus parameter disc which came with the Z80 pack, you will find that the keys have already been set up for you. If, however, you have set up your own parameter file, you will need to set up the keys yourself.

Select 1 from the menu for Amend letter editor parameters.

---

 Amend Letter editor parameters

Cursor left	0
Cursor right	0
Cursor up	0
Cursor down	0
Erase character	0
Insert character	0
Wipe to end of line	0
Open up new line	0
Tab set or cancel	0
File/field insertion	0
Double width on/off	0
Command mode	0
Backspace	0
Tab	0
Carriage return	0

---

You must now type **NRETURN** to allow you to amend the values displayed and type in the following values:

Cursor left	140
Cursor right	141
Cursor up	143
Cursor down	142
Erase character	0
Insert character	0
Wipe to end of line	0
Open up new line	0
Tab set or cancel	0
File/field insertion	0
Double width on/off	0
Command mode	0
Backspace	127
Tab	9
Carriage return	0

Your editing keys will now be set up.

To create your letter:

select 2 from the menu for Create letter program.

Prompt Letter description .....

Type in a description of the letter, followed by **RETURN**, for example, **Sixth form party.**

Select the system and file you want to work on; that is, enter **20** and **1** for the School records system and the Student file.

Prompt **Select next field to be printed (END) ..**

Decide which fields you want to use. The fields in the file you've chosen are displayed below the prompt. As you confirm that the details are correct, Nucleus will mark the field on the screen with a **\*** and prompt you to select the next field to be printed.

Choose fields **1**, **2**, **3** and **4** from the Student file for the Student code, Name, Address and Form number.

If the field you chose is at the primary end of a link you can also choose to print fields from the linked file. This will not happen in the example.

Press **end** when you've finished selecting the fields to be printed.

---

NO	FIELD DESCRIPTION	SYSTEM NAME	FILE NAME
1	Student code	School records	Student file
2	Name	School records	Student file
3	Address	School records	Student file
4	Form number	School records	Student file

---

Confirm that the details are correct and then select the order in which the letters are to be printed.

---

In which order is the report to be printed ? ..

- 1 Student code
  - 99 Other
- 

Type **1** **RETURN** to sort by Student code (or select **99** to specify another print order). The sort details relating to this field will be displayed for you to check and confirm.

---

Do you want to print all records ? (Y/N) .

Selection expression (END)

(More than one expression can be entered on each line)

(Parentheses can be used) Example:- A=1&B<(C+D)\*1.5

\*\*\* Symbols available \*\*\*

= Equal to                    < Less than        <= Less than or equal to        & And  
<> Not equal to            > Greater than    >= Greater than or equal to    ! Or

A Student code  
B Name  
C Address  
D Form number  
E Date of birth  
F Absence to date

---

Type        **N RETURN**

in answer to the prompt to print only selected records, in the example, those for students in form 6.

Prompt    Selection expression (END)

Devise a formula using the symbols and letters displayed beside each field. Nucleus will use this formula to sort which records you want.

Type        **D=6**

Then press **end**, and the formula details will be displayed for you to check and confirm.

When you've finished, Nucleus will automatically make this into a permanent program. Enter a suitable description (up to 30 characters), such as **Sixth form party**, and Nucleus will generate the program in the usual way. You will then return to the letter-writing menu.

## Creating the text of the letter

Select **3** from the menu for Create/amend letter text.

Select **20**, the system number for the School records system.

Prompt Select letter (END) ..

Enter **1** **RETURN** for the number of the letter program you've just produced, called Sixth form party.

Prompt Mount School records program disc on drive B

Replace the Nucleus parameter disc in drive B with the School records program disc and press **RETURN**.

Sixth form party							
AVAILABLE			FILE FIELDS				
CODE	DESCRIPTION	LINES	LENGTH	CODE	DESCRIPTION	LINES	LENGTH
A	Student code	1	4	N		0	0
B	Name	1	30	O		0	0
C	Address	5	30	P		0	0
D	Form number	1	3	Q		0	0
E	Today's date	1	8	R		0	0
F		0	0	S		0	0
G		0	0	T		0	0
H		0	0	U		0	0
I		0	0	V		0	0
J		0	0	W		0	0
K		0	0	X		0	0
L		0	0	Y		0	0
M		0	0	Z		0	0





Prompt Select function: CRE/END

To enter text, press **create**.

Prompt Enter page length (1-80) ..

Enter the number of lines you want on each page. A page length of 66 is normal and we shall use this for the example, so type **66** **RETURN**.



Function	Display	Key
Cursor	L	L or 
Cursor right	R	R or 
Cursor up	U	U or 
Cursor down	D	D or 
Erase character	ERA	E
Insert character	INS	I
Wipe to end of line	WIPE	W
Open up new line	OPEN	O
Tab set or cancel	TSET	T
File/field insertion	FILE	F
Double width on/off	SIZE	D
Command mode	COM	C
Backspace		<b>DELETE</b>
Tab		<b>TAB</b>
Carriage return		<b>RETURN</b>

Note: you can only use the editing functions to work on your text, when the editing options are displayed, and you can only type in text when the editing options are not displayed.

When you want to read in data from the file you've specified, move the cursor to the position in the letter at which you want the data to appear, and press **ESCAPE** to display the options. Then:

press      F

You can then choose, from the displayed list of fields, which field you want by entering the letter beside it.

Today's date is always included in the list and is the date you enter when you use the start-of-day disc each time you print the letter.

Prompt    Field code ? (A-E/CAN)

Type in the letter beside the field you want.



To put the Student code at the top of the letter, with the file fields displayed:

type      **A RETURN**

Prompt    Fixed length ? (Y/N)

Type      **Y RETURN**    if you want all entries on all letters in this field to be the same length or a maximum length

**N RETURN**    if the field can differ in length.

For the example, type **Y RETURN**.

Prompt    Fixed position ? (Y/N)

Type      **Y RETURN**    if you want the information to occupy the same position on every letter

**N RETURN**    if you do not want the position to be fixed.

For the example, type **Y RETURN**.

When you have confirmed that the details are correct you will automatically return to the screen displaying your letter, and you will see that a line of letters has been inserted where you want the Student code to be placed.

You can enter the fields for Name, Address, Form number and To-day's date in the same way. The diagram overleaf gives an indication of the layout and type of letter you can produce.

PARKLANDS SCHOOL

AAAA

BBBBBBBBBBBBBBBBBBBBBBBBBBBBBBBBBB  
C1CCCCCCCCCCCCCCCCCCCCCCCCCCCCC  
C2CCCCCCCCCCCCCCCCCCCCCCCCCCCCC  
C3CCCCCCCCCCCCCCCCCCCCCCCCCCCCC  
C4CCCCCCCCCCCCCCCCCCCCCCCCCCCCC  
C5CCCCCCCCCCCCCCCCCCCCCCCCCCCCC

Dear Student,

DDD - Sixth form party

We shall be holding a Christmas party for all sixth formers on Wednesday 19th December, 1984 at 8.30 p.m. We hope you will be able to come.

Could you please let me know whether you will be able to come, by Friday, 14th December, 1984, at the latest, so that I can make final arrangements for the Christmas supper?

With best wishes,

Frances West  
Head Teacher

To return to entering the main text of the letter, move back to the screen that does not display the editing options, and type in as usual.

At the end of each line of text you must press **RETURN** to go to the next line.

When you have finished typing in your letter and would like to print, save, amend, review or cancel it, press **ESCAPE** to return to the list of editing functions, followed by C. This will return you to the file fields screen.

Prompt    `Select function: AME/REV/PRT/SAV/CAN`

Press	<b>amend</b>	to return to your text to change it
	<b>review</b>	for the text to be scrolled for you to check it
	<b>print</b>	to test print the letter when the printer is ready
	<b>save</b>	to save the text on disc
	<b>cancel</b>	to delete the text.

For the example, press **print** to see a test print of your letter.

Prompt    `Select function: AME/REV/PRT/SAV/CAN`

You can then choose to amend, review, print, save or cancel the letter. If you are not happy with the test print, press **amend** to return to the letter text and alter it.

For the example, press **save** to save your letter and then press **end**.

Prompt    `Mount Nucleus parameter file disc on  
drive B`

Remove the School records program disc from drive B and replace it with the Nucleus parameter file disc. Press **RETURN**.

You then return to the menu.

## Deleting a letter

Select 4 from the menu.

Enter the numbers of the system and letter you want to delete.

Prompt Mount School records program disc on  
drive B

Replace the Nucleus parameter disc in drive B with the system  
program disc, and press **RETURN**.

Message Letter deleted

Your letter is now erased from the disc.

Press **RETURN**

Prompt Mount Nucleus parameter file disc on  
drive B

Remove the School records program disc from drive B and replace it  
with the Nucleus parameter file disc.

Press **RETURN** to return to the menu.

# 12 Producing a document-writing program

---

This chapter explains how to produce a document-writing program.

As in chapter 11, the whole chapter is written as an example for you to try out, and will tell you, keeping within our School records example, how to produce a student absence report.

With the following menu displayed:

---

```
Nucleus - Reporting          PROGRAM MENU

      1. Create M/F print program
      2. Create selected report program
      3. Create label print program
      4. Create letter program
      5. Create document program
```

---

Select 5 from the menu for Create document program.

---

```
Select number (END) .

      1 Amend document parameters
      2 Create document program
      3 Create/amend document text
      4 Delete document
```

---

Option 1 sets up the text editor part of Nucleus for the keyboard you are using. If you are using the Nucleus parameter disc which came with the Z80 pack, you will find that the keys have already been set up for you. If, however, you have set up your own parameter file, you will need to set up the keys yourself.

Select 1 from the menu for Amend document parameters.

---

Amend document parameters

Cursor left	0
Cursor right	0
Cursor up	0
Cursor down	0
Erase character	0
Insert character	0
Wipe to end of line	0
Open up new line	0
Tab set or cancel	0
File field insertion	0
Line position	0
Double width on/off	0
Command mode	0
Backspace	0
Tab	0
Carriage return	0

---

You must now type **N RETURN** to allow you to amend the values displayed and type in the following values:

Cursor left	140
Cursor right	141
Cursor up	143
Cursor down	142
Erase character	0
Insert character	0
Wipe to end of line	0
Open up new line	0
Tab set or cancel	0
File field insertion	0
Line position	0
Double width on/off	0
Command mode	0
Backspace	127
Tab	9
Carriage return	0

Your editing keys will now be set up.

## Setting up the document program

First you establish:

- from which existing Nucleus system you want to take the data to be put into your document
- from which file it is to be taken
- which fields in that file are to be used
- which documents are to be printed.

Select 2 from the menu for **Create document program**.

Prompt **Document description.....**

Type in a suitable description of the document, such as, **Absence report** and press **RETURN**.

Select **20** for the School records system, and the number of the file within that system that you are going to take data from, in this case, choose **2** for the Absence file.

Note: you can only select transaction files.

Prompt **Select next field to be printed (END) ..**

Decide which fields you want to use, from the fields displayed. As you confirm that the details are correct, Nucleus will mark the field on the screen with a **\*** and prompt you to select the next field to be printed.

Choose **1** **RETURN**.

If the field you choose is a linked field (as in the case of Student code, which you have just selected), you will see a display something like this:

---

```
Student code   is linked to School records   Student file

Do you want to print any fields from this file ? .

Select next field to be printed (END)

1 Student code
2 Name
3 Address
4 Form number
5 Date of birth
6 Absence to date
```

---

This gives you the chance to select for printing, fields in the linked file.

Note: when you are asked if you want to print anything from the linked file, if you want the original field you selected to be printed, that is, in this case, Student code, you must select it from the 'linked to' file as well. In the example, we have already selected Student code. We now have to select it again from this screen.

So, in the example, type Y and then choose 1 for Student code and 2 for Name which is not stored in the Absence file. Press **end**.

---

```
Select next field to be printed (END) ..

1 *Student code
2 Date of absence
3 Reason given
4 Length of absence
99 Computed field
```

---

Choose 2 for Date of absence and 4 for Length of absence.

When you've finished selecting fields, press **end**.



---

NO	FIELD DESCRIPTION	SYSTEM NAME	FILE NAME
1	Student code	School records	Student file
2	Name	School records	Student file
3	Date of absence	School records	Absence file
4	Length of absence	School records	Absence file

---

Prompt    **Details OK ? (Y/N/CAN)**

Type        **Y RETURN**    if the details are correct  
               **N RETURN**    to amend the details  
               **cancel**        to erase the details.

For the example, type Y.

---

```

Do you want to print all records ? (Y/N) .

Selection expression (END)
(More than one expression can be entered on each line)
(Parentheses can be used) Example:- A=1&B<(C+D)*1.5
          *** Symbols available ***
= Equal to            < Less than    <= Less than or equal to    & And
<> Not equal to      > Greater than   >= Greater than or equal to ! Or

A Student code
B Date of absence
C Reason given
D Length of absence

```

---

Type        **Y RETURN**    to print all the records.  
message All records will be printed ...

If you want to choose which records are to be printed, type **N** and enter a record selection expression as explained at the end of chapter 10.

Totals on change of Student code

```
Select next field to total (END) ..  
TOTAL DESCRIPTION
```

- 1 Student code
  - 2 Length of absence
- 

Choose the fields you want to total, possibly the Length of absence, field 2, and enter a description, such as `Total absence`.

When you've finished, press **end**.

Nucleus automatically makes this into a permanent program. Enter a suitable program description (up to 30 characters), for example, `Absence report`.

Nucleus now puts your document-writing program on to the program disc containing the system you are working with, and updates your parameter file disc in the usual way.

You then return to the menu.

## Creating the text of the document

Select 3 from the menu for `Create/amend document text`.

Enter 20 for the system number, as you did in the previous option.

Prompt `Select document (END) ..`

A list of the document descriptions is displayed with a number beside each one.

Select 1 for the `Absence report`.

Prompt `Mount School records program disc on  
drive B`

Replace the Nucleus parameter disc in drive B with the School records program disc and press **RETURN**.



Prompt Lowest line number which may be used 0

The screen displays the following information:

---

Comments: Lowest line number means the first printable line at the top of the page, after for example a logo or a preprinted company name

---

Enter the line number where you want printing to start. In the example, type 2 **RETURN**, that is, the lowest or smallest number.

The screen displays all the lines above line 2 as being **UNPRINTABLE LINES**, which means that you cannot start your text in these lines.

Prompt Highest line number which may be used 0

The screen displays the following information:

---

Comments: Highest line number means the number of the last printable line at the bottom of the page, for example;

- if the total number of lines is 66 you may set the highest line to 62 to make sure you get some blank lines at the page end
- 

Enter the line number where you want printing to end, in the example, 60.

The data you have entered is then displayed for you to check and when you've confirmed it's correct, you will see:

---

```
LINE 1/ 0      SET LEFT MARGIN (L/R/'ENTER')
-----!-----!-----!-----!-----!-----!---
```

```
-----!-----!-----!-----!-----!-----!---
```

---

Set the left-hand margin and right-hand margins, by moving the cursor to the place where you want the margin to be and pressing **RETURN**. If you just press **RETURN** the program assumes that you want the margin to be where the cursor is.

In the example, move the cursor to column 10 and press **RETURN**.

Prompt **SET RIGHT MARGIN (L/R/'ENTER')**

The cursor then moves automatically to the right-hand side of the screen for you to choose where you want the right margin to be. In the example, move the cursor back 10 characters and press **RETURN**.

Pressing **RETURN** sets the right-hand margin to the extreme right of the screen.

When you have set the margins for your document, you are ready to begin to type in the text. There are two main screens in this part of the program. The first screen has the heading:

```
Options: 'ESC'      Main text
```

When this heading is displayed, you can type in the text you want for your document.

If you want to edit anything you have typed in, you need to go to the second screen which displays as its heading the list of edit options available. You do this by pressing **ESCAPE**. These are listed below.

Function	Display	Key
Cursor	L	L or ←
Cursor right	R	R or →
Cursor up	U	U or ↑
Cursor down	D	D or ↓
Erase character	ERA	E
Insert character	INS	I
Wipe to end of line	WIPE	W
Open up new line	OPEN	O
Tab set or cancel	TSET	T
File/field insertion	FILE	F
Double width on/off	SIZE	D
Command mode	COM	C
Backspace		<b>DELETE</b>
Tab		<b>TAB</b>
Carriage return		<b>RETURN</b>

You return to the screen for typing in again by pressing **ESCAPE**.

The following diagram shows you what a finished document might look like and what the different parts of the document are called. You should refer to this diagram for clarification and ideas as you work through the rest of this chapter.



The first thing you have to do is to type in the main text of your document. To do this, go to the **Main text** screen.

You may want to type in a heading for the first sheet of the report. In the example, we have typed in **Parklands School and Attendance report** as the first piece of main text on the first sheet of the document (see the diagram).

We then decided that we wanted to head the document with the code and name of the students to whom the absence report referred. This means reading in data from the files we've specified.

To read in data from the file you've specified, move the cursor to the position in the document at which you want the data to appear, and press **ESCAPE** to display the options. Then:

press      **F**

You can then choose, from the displayed list of your chosen fields, which field you want by entering the letter beside it.

Today's date, Page number and Document number are always automatically included in the list. The date is the date you enter when you use the start-of-day disc each time you print the document.

Prompt    **Field code ? (A-H/CAN)**

Type in the letter beside the field you want.

To put the Student code at the top of the document, with the file fields displayed:

type      **A RETURN**

Prompt    **Fixed length ? (Y/N)**

Type      **Y RETURN**    if you want all entries on all letters in this field to be the same length or a maximum length

**N RETURN**    if the field can differ in length.

For the example, type **Y RETURN**.



Prompt Fixed position ? (Y/N)

Type Y **RETURN** if you want the information to occupy the same position on every letter  
 N **RETURN** if you do not want the position to be fixed.

For the example, type Y **RETURN**.

When you have confirmed that the details are correct you will automatically return to the screen displaying your document, and you will see that a line of letters has been inserted where you want the Student code to be placed.

You can enter the field for Name in the same way.

Later in the document, you might want to enter the fields for Date of absence, Length of absence, Total absence, Today's date, Page number and Document number and you do so, using the above method.

If you want to enter a field with more than one line, such as an address, use the same method, but first move the cursor to the place where the field will end, to allow enough room for all the lines.

Having entered the typed-in text and read-in fields of the heading for your first sheet, in the example, you now need to type in the rest of the main text.

Return to the appropriate screen by pressing **ESCAPE** and type in something similar to the text we have shown you in the diagram.

At the end of each line of text you must press **RETURN** to go to the next line.

The transaction file fields in the main text are what are called the repeating lines. In our example, the fields for Date of absence and Length of absence are on the repeating line.

All the above main text will appear only at the top of the first sheet of the document.

We now need to enter the text to appear at the end of the last sheet of the document. To do this, you can specify a line number for the end text to start at. Go to the editing options screen by pressing **ESCAPE** and then

```
type      N
```

```
Prompt  Next line commences at page line ..
```

Bearing in mind that we have selected a page with 66 lines, and we want this piece of the main text to appear at the bottom of the last sheet, entering 45 would be suitable.

Press **ESCAPE** and then type in the text.

When you have finished typing in all this main text, press **ESCAPE** and then type C. You will see:

```
message  Disc access - please wait
```

and then

```
message  Checking text
```

You then return to the display showing your document format.

When you have confirmed that your format details are correct, you will see:

---

```

-----
 1///UNPRINTABLE LINES ///
 2
-> >>> Page header <<<< <-
                                     Do you want to enter/amend continuation
                                     page headers or footers ? .
                                     Your text may exceed one page in length
                                     You may enter additional lines of text
                                     to be used for :
                                     - page continuation (footers) and
                                     - continuation page headers
                                     whenever an extra page generated
                                     (Note: When specifying a page number
                                     please use the page number field;
                                     do not type an actual page number !)
-----
-> >>> Page footer <<<< <-
                                     60
 61///UNPRINTABLE LINES///66
-----

```

Prompt Do you want to enter/amend  
continuation page headers or footers ?

If you want your pages to have headers and footers you answer Y to this prompt and you will be prompted to enter in the text for these headers and footers later.

For the example, type Y **RETURN** and then type Y to confirm the details.

---

<pre> 1////UNPRINTABLE LINES /// 2 &gt;&gt;&gt;&gt; Page header &lt;&lt;&lt;&lt;  -&gt; !!!!REPETITION LINES !!!!  &gt;&gt;&gt;&gt; Page footer &lt;&lt;&lt;&lt; 60 61////UNPRINTABLE LINES///66 </pre>	<p>Repetition will be from text line 10 to text line 10</p> <p>Certain lines of your text will be repeated until all data from transaction files has been printed. You may specify extra lines for inclusion in this repetition by amending displayed values. You also have the option of entering lines of text to be used as headers and footers to this data if a continuation page is required (eg.: 'Carried forward' and brought forward' data or column headings.)</p>
---------------------------------------------------------------------------------------------------------------------------------------------------------------------------------------------------------	-----------------------------------------------------------------------------------------------------------------------------------------------------------------------------------------------------------------------------------------------------------------------------------------------------------------------------------------------------------------------------------------------------------------------------------------------------------------------------------

---

Prompt Repetition will be from text line 10  
to text line 10

The area in which lines of text are repeated, is the area where all the details in the transaction file are printed out — in our example, this will be all the dates and lengths of absence.

Press **RETURN** twice.

```

-----
1///UNPRINTABLE LINES /// Do you want to enter/amend data headers
2 or footers ?
>>>> Page header <<<<
-----
-> | Data header | <- Certain lines of your text will be
| | | | <- repeated until all data from
----- <- transaction files has been printed
!!!!REPETITION LINES !!!! You may specify extra lines for
| | | | <- inclusion in this repetition by amending
----- <- displayed values. You also have the
-> | Data footer | <- option of entering lines of text to be
| | | | <- used as headers and footers to this
----- <- data if a continuation page is required
>>>> Page footer <<<< <- (eg.: 'Carried forward' and brought
| | | | <- forward' data or column headings.)
-----
61///UNPRINTABLE LINES///66
-----

```

Prompt Do you want to enter/amend data headers or footers ?

Type **Y** **RETURN** to enter headings and footers for your data and refer to the diagram for an example of what to type in.

You will then be prompted to enter the text for the data footers and headers, followed by the page footers and headers. After you have typed in each piece of text, press **ESCAPE** followed by **C**.

Make sure to move the cursor to the position where you want the footers and headers to appear on the page, before you type in the text.

When you have entered all the page and data headings and footers, you return to the file fields screen.

Prompt Select function: **AME/REV/PRT/SAV/CAN**

Press **amend** to return to your text to change it  
**review** for the text to be scrolled for you to check it  
**print** to test print the letter when the printer is ready  
**save** to save the text on disc  
**cancel** to delete the text.

For the example, press **print** to see a test print of your report.

Prompt `Select function: AME/REV/PRT/SAV/CAN`

You can then choose to amend, review, print, save or cancel your report. If you are not happy with the test print, press **amend** to return to the document text and alter it.

For the example, press **save** and then press **end**.

Prompt `Mount Nucleus parameter file disc on  
drive B`

Remove the School records program disc from drive B and replace it with the Nucleus parameter file disc. Press **RETURN**.

You then return to the menu.

## Deleting a document

Select 4 from the menu.

Enter the numbers of the system and document you want to delete, which, for the example, will be 20 and 1.

Prompt `Mount School records program disc on  
drive B`

Replace the Nucleus parameter disc in drive B with the system program disc, and press **RETURN**.

Message `Document deleted`

Your document is now erased from the disc.

Press **RETURN**

Message `Mount Nucleus parameter file disc on  
drive B`

Replace the School records program disc with the Nucleus parameter file disc and press **RETURN** to return to the menu.

# 13 Printing details of your files

---

Programmers using Nucleus will want to print out details about their files which are not usually needed when you design systems using Nucleus.

Option 5 on the Nucleus Definition menu gives you a permanent record of your file details which is useful if you want to change the programs later on.

Your printout gives you extra information about your files which is produced automatically by Nucleus, such as the **BASIC filename**, the position of each field within the record, called the **Start Byte Number**, and a **BASIC variable name** for each field within a file.

Print out the file definitions for each program you work on and store them with the notes you've prepared on how to use the program.

Select 5 from the program menu for `Print file definitions`.

Prompt `Select system (ALL)`

Type `<system number or ALL>` **RETURN**

The files and their numbers in the system you've selected are displayed.

Prompt `Select file (ALL)`

Check that the printer is ready.

Type `<file number or ALL>` **RETURN**

Message `Printing in progress`

When all the printing you have asked for is finished, you will go back to the program menu.

# 14 Amending menus

---

If you want to put your company name on the company menu, or you want to change one of the menus of a program you have generated, you do so, using the method detailed below.

You should not, however, change any of the menus that make up the Nucleus program itself.

To enter your company's name into the company menu, make sure the company menu is displayed on your screen and then:

press **amend**

The menu will disappear for a moment and then reappear with a dotted line next to option 2.

Type **1 RETURN**

Prompt Enter COMPANY description - 'DEL' to delete

The cursor moves to the first character of the company name in option 1.

Type <your company name> **RETURN**

The cursor moves to the first digit of the company number. Do not change this, just:

press **RETURN**

Prompt **'END'** To end maintenance

The cursor is now at the **Select** number position.

Press **end**

# 15 Using passwords

---

If you want to protect certain sections of your program from access by other people, you can do so by using the password system.

You can set a password at all the menu levels and an overall protection is provided by the master password.

To set a password, make sure that the menu you want is displayed on the screen.

Type      **PWD****RETURN**

Prompt    Do you want to change master  
password ? (Y/N)

Type      **Y****RETURN**    to change the master password  
**N****RETURN**    to leave the master password unchanged.

If you type Y, you will see:

prompt    Enter old password (maximum 3 characters)

Type      <old master password>**RETURN**

Note: what you type will not appear on the screen, for the sake of security, so you must make absolutely sure that you type the correct password, using, not only the correct characters, but also the correct upper and lower case.

Prompt    Enter new password (maximum 3 characters)

Type      <new master password>**RETURN**

This will also not appear on the screen, for the same reason, so, once again, it is important to be accurate.



Prompt Check new password (maximum 3 characters)

Type <new master password> **RETURN**

and you return to the menu you originally had on the screen at the **Select number:** prompt.

If you don't want to change the master password, or you have already changed it and now want to set passwords for separate companies, systems or programs, when you see:

prompt Do you want to change master  
password ? (Y/N)

type **N RETURN**

Prompt Enter master password

Type <the master password> **RETURN**

A new column will then appear on the screen, to the right of the menu you have displayed, with the heading **COMPANY PASSWORD**, **SYSTEM PASSWORD** or **PROGRAM PASSWORD**, depending upon what level of menu you are in.

Prompt **Select number:**

Type <number> **RETURN**

where <number> is the number of the company, system or program you want to protect with a password.

A dotted line will appear in the new column next to the option where you want to set the password.

Type <password> **RETURN**

This password will be displayed, for you to check, and you can then enter passwords for the other options on the displayed menu in the same way.

Note: typing spaces for the password will either delete a password you have already set for that option, or leave an option which does not already have password protection, still unprotected.

When you have set all the passwords you want at this level of menu, press **end** to stop the operation.

You can then set passwords at other menu levels, or return to using Nucleus.

When the passwords have been set, every time that you or anyone else, selects an option with password protection, you will see:

prompt Please enter password (maximum 6  
characters)

Type <password>**RETURN**

Message Password correct

If you type in the wrong password, you will see:

prompt PASSWORD IS INCORRECT - TRY AGAIN ? (Y/N)

You can then enter the correct password, or, if you don't know the password, you can return to the menu, but you will not be able to enter that option.

Note: the master password on the program when you receive it is **XXX**. To make your system secure, you should change this to your own master password. No passwords are set on the company, system or program menus.

# Error messages and potential pitfalls

---

## Error messages

Nucleus displays several messages to help you use the system and avoid making mistakes. Most of these are self-explanatory. We have listed here those which may need a little extra explanation.

### LAST UPDATE ABORTED RETURN TO BACKUP

You have left the program you are using, in some way other than via the company level menu, for example, through a power failure. You must return to the most recent back-up copy of your discs.

### INVALID INPUT

You have tried to enter data in a form which is unacceptable for the program. Check on the field definition required and type the entry again.

### NO COMPANY MENU EXISTS ON DRIVE B

You are using a new disc in drive B. To create the menu structure which Nucleus needs follow the instructions on page 109 of this guide.

### INVALID FIELD TYPE

You have entered something other than A, N, D, or R for the field type.

### RECORD LENGTH EXCEEDS 251

The total number of characters you have defined for the fields in a record is more than the maximum allowed, 251. You will have to start defining the file again, reducing the size of the fields to bring the total to less than 251.

### MAXIMUM KEY LENGTH IS 26

You have tried to set up a key with more than 26 characters. If this field must be a key, you will have to define the file again making the field length shorter.

### MAXIMUM NUMBER OF RANKS IS 5

You have tried to sort using more than five different methods.

### **INVALID EXPRESSION**

You have entered a sorting expression which is unacceptable. Establish why the expression is invalid and enter a new one.

## **Potential pitfalls**

This section lists the points to watch when setting up your Nucleus programs. If you see an error message and you are not sure what you have done wrong, check to see if it is explained here.

### **Field definition**

You cannot delete protect an alpha field, only a numeric one.

You cannot automatically update an alpha field, only a numeric one.

You must answer the **Allow negative values** prompt.

The total size of a single record must not exceed 250 bytes. If it does, you will see an error message.

### **Setting up keys and links**

You cannot make a field into a key if it has more than one line.

You cannot update automatically a field defined as a principal key.

You must have a key at the secondary end of a link.

Once you have accepted a file and field definition you cannot change it.

### **Producing updating programs**

When you're writing a reporting program using a linked field, you must select the linked field you want to print, both from its own file and the linked file. If not, it will not be printed.

**Entering data**

You must have data in a file your validating against before you can run the updating program for the primary file. Because of this you must not set up validating links in both directions as this would mean you could not put data into either file.

You cannot leave a numeric field empty. If you have no information to put in it, enter zero.

**Nucleus Reporting**

You cannot use a date field in a sorting expression, since Nucleus reads the / symbols between the day, month and year as division signs.

**Temporary programs**

If the program is to be temporary, you should already have run the `File creation` program to create the files that this program is to use. If you have not, you will see:

message `File XXX not found. CAN to cancel`

and you will then have to go back to run `File creation` and start again.

# Glossary

---

This glossary covers the terms used in the Nucleus guide and is for reference only. All these terms are explained when you first come across them in the guide.

If there are any general computing terms you are not sure of, check in the glossary in the *Z80 user guide*.

## **alphanumeric**

Data consisting of numbers from 0 to 9, letters and other special characters on the keyboard.

## **cursor**

The bright rectangle on the screen which shows where the next character you type will appear.

## **default**

A standard setting, built into the program, but often adjustable by you.

## **field**

The area within a computer record which stores information in a pre-set form.

## **file**

The data stored using a system generated by Nucleus is organised into files, each with its own file name.

## **key**

A field in Nucleus file which has been set up as an index tab. The program uses keys to sort your records and link files together.

## **master file**

A file containing records each of which has a unique key. When you edit a master file record you write over what is already there. For example, the name and address of all the employees stored in a personnel records system.

**numeric**

Data consisting only of numbers: from 0 to 9, positive or negative.

**record**

A group of related items of data stored together on a disc and processed by the computer as one unit. A record is made up of a number of fields. For example, all the information on one employee in a personnel records system would be in one record with its own key.

**transaction file**

A file which holds records of sequences of events. When you add data to a transaction file it is added to the record, it does not overwrite the information already there. For example, the records of the number of days holiday an employee has taken would be in a transaction file.

**update**

To put information into a file, whether you are changing existing records or adding new ones. You run the updating program when you enter data to the files.

**validation**

Checking when data is entered to your records to make sure that the information is correct, and is in the form specified by the program.

# Index

---

calculated values	64	files	11
choosing		creating	25, 31
data	63	defining	22
records	63	linking together	50
computed field	64, 71	naming	22
creating files	36	parameter	22
data		finishing	22
disc	35	footer	
entering	17	data	101–106
printing	17	page	101–106
sorting	44	generating programs	8, 25, 32
storing	11	header	
database	7	data	101–106
discs	17	page	101–106
data	35	keyboard keys	
parameter file	17	for text editing	81, 92
program	9, 17	keys	
documents	91	for sorting	44
creating program	93	in links	42, 43
deleting	107	planning	41
designing program	67	principal	30
text of	96	setting up	30, 50
error messages	113	labels	66, 76
fields	14	print order	78
as a key	30, 41–44	size	77
defining	14, 15, 26–30	letters	62, 67
planning	13, 14	creating program	80
types	27	deleting	90
file structures	11–14	text of	84
filenames	108		



- |                     |            |                       |           |
|---------------------|------------|-----------------------|-----------|
| linking files       | 50–52      | programs              |           |
| links               | 41–44, 47  | designing             | 11        |
| direction of        | 43, 45     | document-writing      | 67, 91    |
| primary             | 43         | label-printing        | 66, 76    |
| secondary           | 43         | letter-writing        | 67, 80    |
| setting up          | 47–50      | master file print     | 37, 62    |
| master file print   | 37–38      | Nucleus               | 9         |
| master files        | 26, 44     | planning              | 13        |
| menus               | 9, 10      | report-writing        | 65, 69    |
| amending            | 109        | running               | 8, 35, 59 |
| creating            | 24         | updating              | 9, 32, 52 |
| filling in          | 10         | writing               | 7         |
| messages            | 18         | your own              | 8, 18     |
|                     |            | prompts               | 18        |
| naming              |            | reports, types of     | 62        |
| files               | 25         | running programs      | 8, 35, 39 |
| systems             | 23         |                       |           |
| order of print      | 73         | secondary field       | 43        |
| organising files    | 11         | selecting             |           |
|                     |            | data                  | 78        |
| parameter file disc |            | print order           | 73        |
| creating            | 22         | records               | 78        |
| passwords           | 110        | selection expressions | 63        |
| planning programs   | 11, 41     | starting              | 20        |
| primary field       | 43         | structuring           | 11        |
| principal key       | 30         | system                | 11        |
| printing            | 9          | naming                | 24        |
| document            | 67, 91–107 | prefix                | 24        |
| file details        | 108        | selecting             | 32        |
| from Accountant     | 68         | test display          | 34        |
| labels              | 66, 76–78  | test prints           | 72        |
| letters             | 67, 80–90  | text                  |           |
| reports             | 37, 62–78  | for documents         | 96        |
| test prints         | 72         | for letters           | 84        |
| totals              | 75         | transaction files     | 44        |
| problem solving     | 113        |                       |           |

updating	
automatically	57
programs	32, 46, 52
selected fields	53
validation	41-43, 57



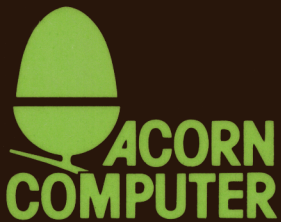

Acorn Computers Limited, Fulbourn Road, Cherry Hinton, Cambridge CB1 4JN, England

Printed by Saunders & Williams (Printers) Ltd, Croydon, Surrey